

Wheeled Paver

SUPER 1603-3

Universal Class



Maximum Pave Width 6.5m
Maximum Laydown Rate 600t/h
Transport Width 2.55m

The Highlights of the New Generation

» The "PaveDock Assistant" enhances process safety during transfer of the mix

» ErgoPlus 3 with a number of additional ergonomic and functional advantages

» Powerful Cummins engine of the very latest generation

» "VÖGELE EcoPlus" low-emissions package significantly reduces fuel consumption and noise levels

» "AutoSet Plus" functions permit a quick and safe move of the paver on the job site and the saving of individual paving programs



The Compact Wheeled Paver



Innovative paving technology can come in compact packages, as the SUPER 1603-3 from VÖGELE proves. A member of the "Dash 3" paver family, it is one of the most advanced wheeled pavers in its class.

Naturally, the SUPER 1603-3 benefits from all the new "Dash 3" features. For instance, the "VÖGELE EcoPlus" package reduces fuel consumption and noise emissions significantly. In addition, VÖGELE's ErgoPlus operating system has been supplemented with many ergonomic and functional features: ErgoPlus 3 is now equipped

with a particularly large colour display in the paver operator's console, ensuring brilliant readability even in poor lighting conditions. The "AutoSet Plus" and the "PaveDock Assistant" features additionally simplify working with the SUPER 1603-3. With its compact dimensions and an extremely small outside turning radius thanks to the „Pivot Steer" steering brake,

the SUPER 1603-3 is particularly manoeuvrable and hence suitable for a wide range of applications. It is the perfect paver in the Universal Class.

Economical and Eco-Friendly “VÖGELE EcoPlus” Package

Saving Fuel with “VÖGELE EcoPlus”

The philosophy behind the drive concept of the “Dash 3” generation is: “Lower consumption – lower emissions – lower costs”. In this respect, the innovative “VÖGELE EcoPlus” low-emissions package includes a whole series of measures to significantly reduce fuel consumption and noise levels.

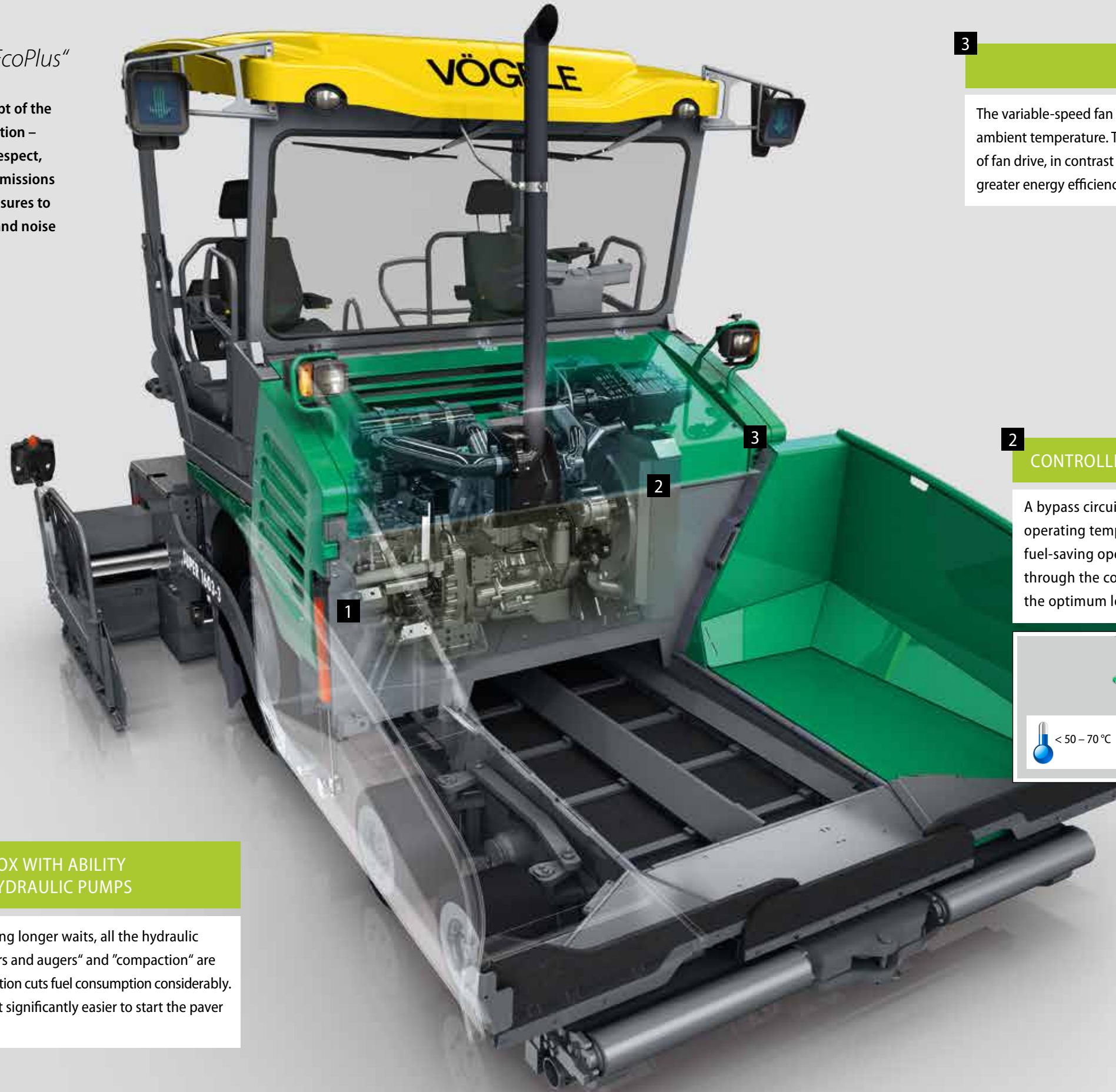

1 SPLITTER GEARBOX WITH ABILITY TO DISENGAGE HYDRAULIC PUMPS

When the paver is stationary, e.g. during longer waits, all the hydraulic pumps needed for “traction”, “conveyors and augers” and “compaction” are automatically disengaged. This new function cuts fuel consumption considerably. Reducing the trailing load also makes it significantly easier to start the paver at low ambient temperatures.

3 VARIABLE-SPEED FAN

The variable-speed fan automatically adapts to the engine load and the ambient temperature. The fan is driven via a viscous coupling. This new type of fan drive, in contrast to a hydraulic drive, stands out through considerably greater energy efficiency and much lower noise levels.

2 CONTROLLED HYDRAULIC OIL TEMPERATURE CIRCUIT

A bypass circuit allows the hydraulic oil to reach its optimum operating temperature very quickly. This in turn permits rapid, fuel-saving operation of the paver. The hydraulic oil is not led through the cooler assembly before its temperature has exceeded the optimum level of 50 – 70 °C.

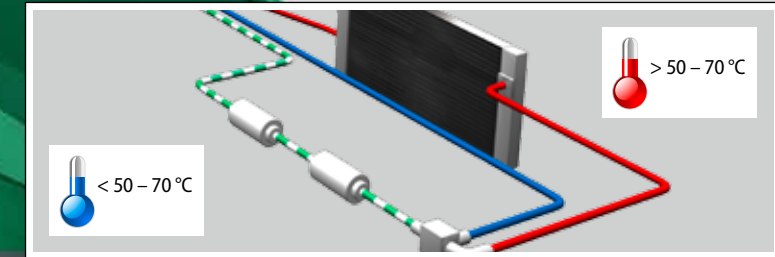

Automated Processes with “AutoSet Plus”

1

“AutoSet Plus”: The Repositioning Function

- » Fast and safe repositioning of the paver on the job site.
- » No settings are lost between paving and repositioning.
- » Also prevents any damage to the augers.

2

“AutoSet Plus”: The Paving Programs

- » Automated configuration of the paver.
- » Stores all paving-relevant parameters.
- » Selection of stored paving programs.
- » Reproducible quality.



With “AutoSet Plus”, we have enhanced the efficiency, convenience and quality of key job site processes. “AutoSet Plus” has two handy automatic functions.

The repositioning function greatly facilitates the continuation of work when moving the paver on

the job site from one work section to another, or after the paver has been transported. Simply pressing the “Execute” button quickly and reliably readies the machine for travels on the job site, or for transport. Pressing the button again returns it to the previously stored working position.

The “Paving Programs” function allows the operating personnel to save the configured machine parameters and store these as a paving program in the menu. This program can then be called up and used whenever needed.

The two comfort functions of “AutoSet Plus” automate routine tasks, allowing work processes to be carried out more quickly and with greater control. This in turn means that construction projects can be completed faster and more reliably.

“AutoSet Plus” Repositioning Function



The “AutoSet Repositioning Function” is activated just by pushing the “Execute” button.



2 Lock/unlock screed



4 Conveyor movement reversible for a short time



1 Raise/lower screed

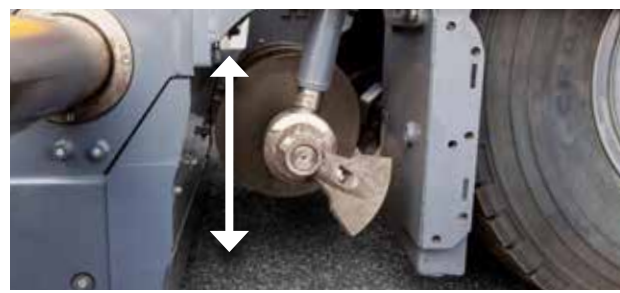

3 Raise/lower auger



5 Raise hopper front

“AutoSet Plus” is especially helpful when the machine frequently has to be moved on the job site.

Simply pressing the “Execute” button raises the augers and the hydraulically operated hopper front to the uppermost positions. The screed is brought into its transport position and hydraulically locked. The conveyors are temporarily reversed, preventing mix falling to the ground when the paver travels to the next work section on site.

Once the paver has been repositioned, pressing the “Execute” button again returns all systems to the previously stored working position.

This ensures that no settings are lost when changing from paving to repositioning or transport. It also effectively prevents any damage to the machine.

“AutoSet Plus” Paving Programs



The automatic function for paving programs allows the operating personnel to store their own paving programs. All key parameters for paving a specific layer (example: asphaltic concrete base, 18cm thick) can thus be saved.

The paver operator stores the configured values for the compacting systems (tamper and vibrator speed), the auger height, the position of the screed tow points, Screed Assist and the pave speed in the program via the display on the paver operator’s console. He also enters the amount of crown and the screed temperature.

The program is completed with additional information on the material being used, the layer thickness and the pave width.

The stored paving programs can subsequently be selected and used at any time via the menu. In the event of a repeat situation, this ensures that work is carried out with exactly the same settings while maintaining a consistent quality.

Increased Mobility Thanks to "Pivot Steer"

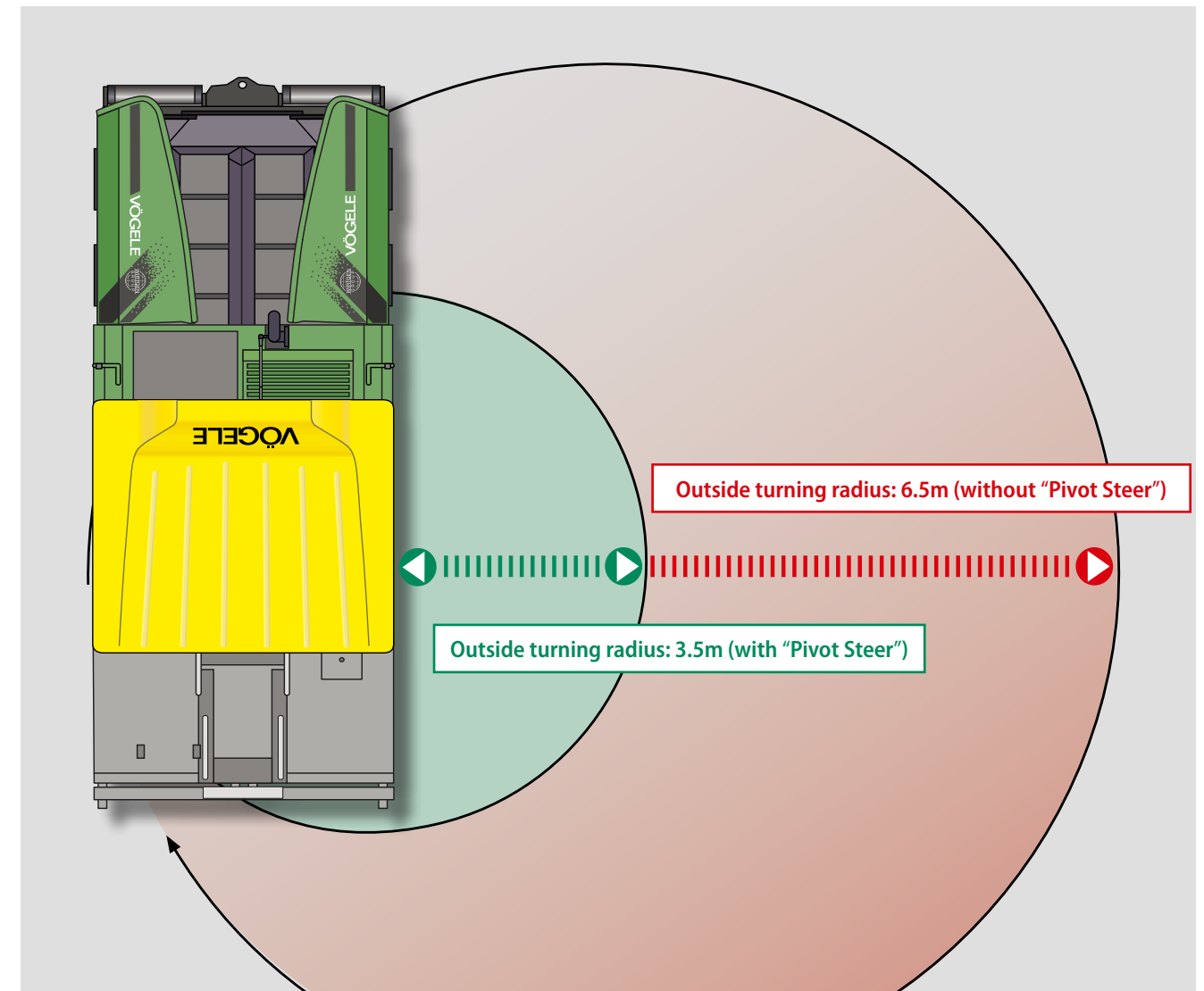

The "Pivot Steer" steering brake reduces the torque of the rear inner wheel on "Dash 3" pavers, enabling them to turn almost on the spot. „Pivot Steer“ diminishes the outside turning radius of the SUPER 1603-3 to as little as 3.5m.

The function can be activated in Job Site Mode for either forward or reverse travel and greatly improves the manoeuvrability of the machine on cramped job sites.

» Small outside turning radius of just 3.5m makes for simple manoeuvring, even on cramped job sites.

» The short overall length of the SUPER 1603-3 saves the paver operator unnecessary manoeuvres, even in tight spaces.



“PaveDock Assistant”: The Communication System

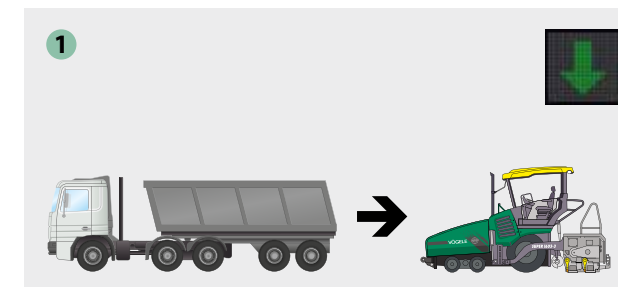

Dock: Lorry drives up to the paver and docks.

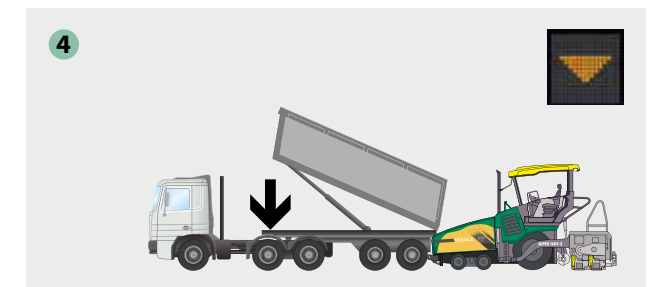

Lower Dump Box: Lorry lowers the dump box.



Stop: Lorry must halt. It has docked.



Drive Off: Lorry drives away from the paver.

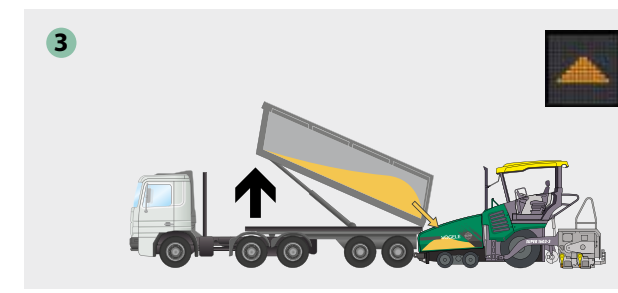

Raise Dump Box: Lorry raises the dump box.

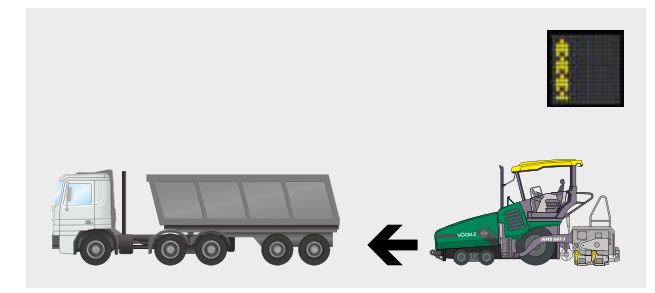

Paver is moving: Symbol can appear together with all symbols.

“PaveDock Assistant” is the communication system between the paver operator and the feed vehicle driver. It allows particularly fast and reliable transfer of mix to the paver.

The “PaveDock Assistant” communication system contributes greatly to process safety during transfer of the mix.

The core element of the “PaveDock Assistant” are the signal lights on the paver and the associated control elements on the ErgoPlus 3 paver operator’s console. The paver has two sets of signal lights, mounted on the right and left of the hardtop. With these lights, the paver operator can give the driver of the feed vehicle unmistakable signals, indicating what needs to be done (e.g. reverse, stop, dump mix). Having two lights, each in an elevated position, ensures that all signals are clearly visible to the feed vehicle driver from all angles of approach.

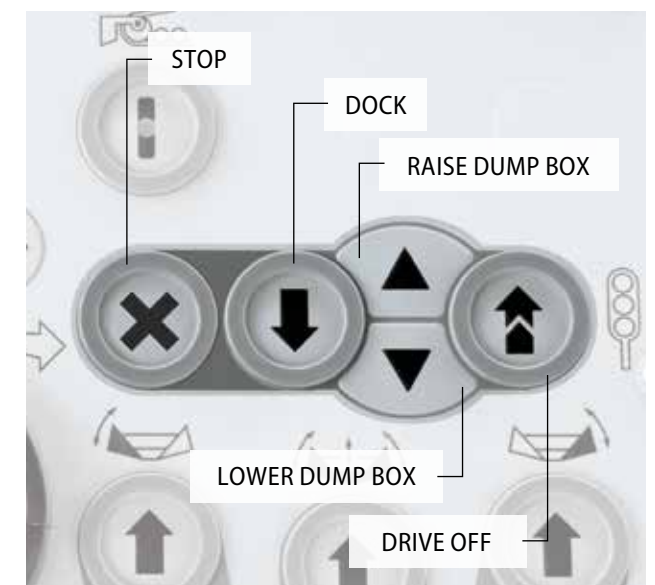

VÖGELE ErgoPlus 3

The User-Friendly Operating System

Even the very best machine with the most advanced technology can only really show its strengths if it can be operated easily and as intuitively as possible. At the same time, it should offer an ergonomic and safe working environment for the operating team. Therefore, the ErgoPlus 3 operating concept focuses on the operator.

On the following pages you will find detailed information on the extensive functions of the ErgoPlus 3 operating concept. ErgoPlus 3 encompasses workplaces for the operator's stand and the screed – i.e. the paver operator's console and screed console – and Niveltronic Plus, the System for Automated Grade and Slope Control.

The operating consoles are designed for optimum clarity, presenting all paver functions in logical groups. There's a place for everything and everything in its place on the operator's stand, and the paver operator has an excellent overview of all the key points of the paver.

All told, the ErgoPlus 3 operating concept enables the operators to respond to job site working processes and situations more quickly and accurately, giving them total control over the machine and the project.

The Major Advantages of ErgoPlus 3

- » Clearly arranged and tidy workplaces offer a high degree of safety.
- » The paver operator's seats and the operating console are adjusted conveniently and easily to meet his personal needs. This provides a maximum of ergonomic comfort.
- » All vital paver functions are clustered in logical groups on the paver operator's console. Their operation is quick and easy to learn.
- » Easy operation of VÖGELE Niveltronic Plus, the fully integrated System for Automated Grade and Slope Control, to achieve perfect paving results.
- » The ErgoPlus 3 paver operator's console is of modular design. This smart concept is not only ideal in practice, but also saves costs. It offers the great advantage that single modules can be replaced if necessary without needing to replace the entire unit.

New Developments in ErgoPlus 3

- » The paver operator's console comes with a large colour display ensuring brilliant readability even in poor lighting conditions.
- » On the operator's platform, side panelling affords effective protection from the wind and rain.
- » Thanks to their sturdy design, the screed consoles are well equipped to deal with tough job site conditions.
- » "SmartWheel" for precise screed width control in two speeds.
- » Ergonomic and safe working with the newly designed screeds.



Paver Operator's ErgoPlus 3 Console



ErgoPlus 3 Screed Console



Ergonomic ErgoPlus 3 Workplaces

The Paver Operator's **ErgoPlus 3** Console

Full Control for the Machine Operator



The Paver Operator's ErgoPlus 3 Console

Clear and Logical Arrangement of Controls

Examples of Paver Functions

Reversing Conveyor Movement

In order to avoid mix dropping from the conveyors during a move of the paver on the job site, conveyor movement can be reversed at the push of a button. Reverse movement, transferring mix from the rear of the conveyor tunnel back inside, takes place for a short time only and stops automatically.



No-Load Function

The No-Load Function is provided for the warm-up or cleaning of conveyors, augers and tamper.



"AutoSet Plus" Repositioning Function

With the "AutoSet Plus" repositioning function, the paver is quickly and safely prepared for a move on the job site at the push of a button. After the move, all paver components are reset to their previous working positions, simply by pressing the button again. This ensures that no settings are lost when changing between "Pave" and "Job Site" modes. "AutoSet Plus" also effectively prevents damage during transport.



Choice of Operating Modes for the Paver

On the ErgoPlus 3 console, 5 different operating modes for the paver are available to select from. By pressing the arrow buttons, up or down, the operator changes modes in the order as follows: "Road Travel", "Neutral", "Job Site Mode", "Positioning Mode" and "Pave Mode". An LED indicates the mode selected. When leaving "Pave Mode", a smart Memory feature stores the last settings for paver functions so that, when resuming work after a move of the paver on site, these settings are restored automatically.



The paver operator's ErgoPlus 3 console has been designed according to practice-related principles. All controls are clearly arranged. Paver functions are clustered in logical groups so that operators find their controls just where they would expect them to be.

On the ErgoPlus 3 console, all push-buttons are easily identifiable by touch even when wearing work gloves. Once a button is pressed, off you go. This is due to the "Touch and Work" principle. This means that a function is executed directly – without a need to confirm. As darkness falls, the paver operator's console is back-lit automatically, as in a car. This makes night-time work easy and relaxed.



MODULE 4

Display for set-up of vital paver functions on menu level 1. Secondary functions on menu level 2.

Display of the Paver Operator's Console

The redesigned colour display has a high-contrast user interface ensuring brilliant readability even in poor lighting conditions. Vital information is shown on menu level 1, such as the positions of the screed tow point rams or the material level in the conveyor tunnel. Further paver functions such as speeds for tamper and vibrators or feed rate for the conveyors can easily be set up via the display, too. And the display gives access to machine-related information such as fuel consumption or service hours.



"PaveDock Assistant" (Option)

With the "PaveDock Assistant" signal lights, the paver operator can give the driver of the feed vehicle unmistakable signals, indicating what needs to be done (e.g. reverse, stop, dump mix). The lights are conveniently activated directly from the paver operator's ErgoPlus 3 console.



Choice of Engine Speed Ranges

For the engine, there is a choice of 3 modes to select from: MIN, ECO and MAX. To switch modes for engine rpm, all the operator needs to do is press the arrow buttons, up or down. In ECO Mode, the engine delivers sufficient power for a great number of paving applications. Operating in ECO Mode reduces noise emission and fuel consumption considerably.



Screed Assist (Option)

This button switches Screed Assist on (LED lights up) or off. Screed Assist pressure and balance can be set via the display. Screed Assist is active only when the screed is floating.



MODULE 1

Conveyors and Augers, Traction

MODULE 3

Material Hopper and Steering

MODULE 2

Screed

The ErgoPlus 3 Screed Console

The screed is crucial for pavement quality. Therefore, easy and positive handling of all screed functions is of the utmost importance for high-quality road construction.

With ErgoPlus 3, the screed operator has the process of paving at his fingertips. All functions are easily comprehensible and all controls are clearly arranged.



The Screed Console

The screed console is designed in keeping with the conditions prevailing on the job site. Push-buttons are provided for the frequently used functions operated from the screed console. These are watertight and enclosed in palpably raised rings, so that they are identifiable blindfold simply by touch even when wearing work gloves. Important paver and screed data can be called up and adjusted from the screed console, too.



The Display of the Screed Console

The display of the screed console allows the screed operator to control and monitor both the left and the right side of the screed. Machine-related parameters such as tamper speed or conveyor speed can be adjusted conveniently via the display panel of the screed console. The clear menu structure, combined with easily understandable, self-explanatory symbols neutral in language, makes operating the display panel both simple and safe.

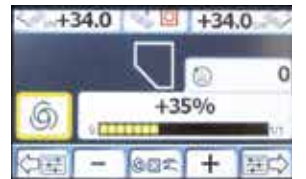

Niveltronic Plus (Option)

Niveltronic Plus, the cutting-edge VÖGELE System for Automated Grade and Slope Control, is very easy to learn and achieves outstanding paving results. All important functions of Niveltronic Plus can be accessed directly on menu level 1. The operator is provided with a variety of information, such as the sensor currently selected or the specified and actual values for layer thickness.

An electronic system installed in the screed tow point rams picks up the tow points' positions. Display of the current tow point positions and of the transverse slope on the screed console greatly facilitates set-up of the screed. All sensors connected are recognized automatically by Niveltronic Plus and can be monitored and controlled from either screed console. An open interface is provided for connection of a GPS system, thus permitting 3D paving.



Crown Adjustment at the Press of a Button

The crown can be conveniently adjusted at the press of a button on the screed operator's console. When pressing the "plus" or "minus" keys, the set crown value is shown on the display.



Ergonomic Screed Width Control in Two Speeds

The screed width can be effortlessly adjusted by means of the handy "Smart Wheel". This can be done in two speeds: slow, for precise control e.g. along an edge, or fast, for rapid extension and retraction of the screed.



Ergonomic Workplace: The Operator's Stand



Excellent All-Round Visibility

» The comfortable operator's stand gives an unobstructed view of all crucial areas on the paver such as material hopper, steering guide or screed. It allows the paver operator to closely monitor the paver's feed with mix and the process of paving.

» The seats swinging out to the sides and an operator's stand of streamlined design provide for maximum visibility of the auger tunnel, permitting the paver operator to keep an eye on the head of mix in front of the screed at all times.



Working Comfort

» On the "Dash 3" machines, the paver operator's seat and console, as well as the screed consoles can now be adjusted even more easily to personal needs. The paver operator's console can be displaced across the full width of the operator's stand, swivelled out to the sides and tilted. Side panelling affords effective protection from the wind and rain.

» When working with the seat swung out, the paver operator's console can be swivelled out together with the operator's seat. In this way, an ergonomically optimized workplace is set up in no time at all.



A Place for Everything and Everything in its Place

» The operator's stand, with its streamlined design, is well organized, offering the paver operator a professional workplace.
 » The operator's console can be protected by a shatter-proof cover to prevent wilful damage.
 » Plenty of stowage space makes it easy to keep the machine tidy. Access to all vital service points on the machine has been designed to be extremely clear and ergonomic.

Hardtop Gives Excellent Protection

» The modern hardtop made of glass fibre reinforced polymer material shelters the operator come rain or shine. The hardtop, including exhaust pipe, is raised or lowered quickly and with effortless ease by a manually operated hydraulic pump. Wide, easily extendable sunshades give the operator optimal protection when his seat is moved out.
 » Six bright working lights are integrated into the hardtop. Raising the lights in this way floods the job site with light (xenon lamps available as an option).



Ergonomic Workplace: The Screed

New Walkway and Ascent

» The ergonomic walkway and low steps leading to the operator's stand are safe and very convenient.
 » An additional folding step makes for even more comfort. The ascent is as safe and easy to negotiate as a staircase.
 » All steps are visible from above.



Soundproofing

» Covers, walkway and ascent are rubber-cushioned to reduce noise.



Ergonomic Screed Console

» Easy to adjust.
 » The high-contrast colour display can be read clearly from all angles.
 » "Smart Wheel" for fatigue-free screed width control.





Modern Drive Technology

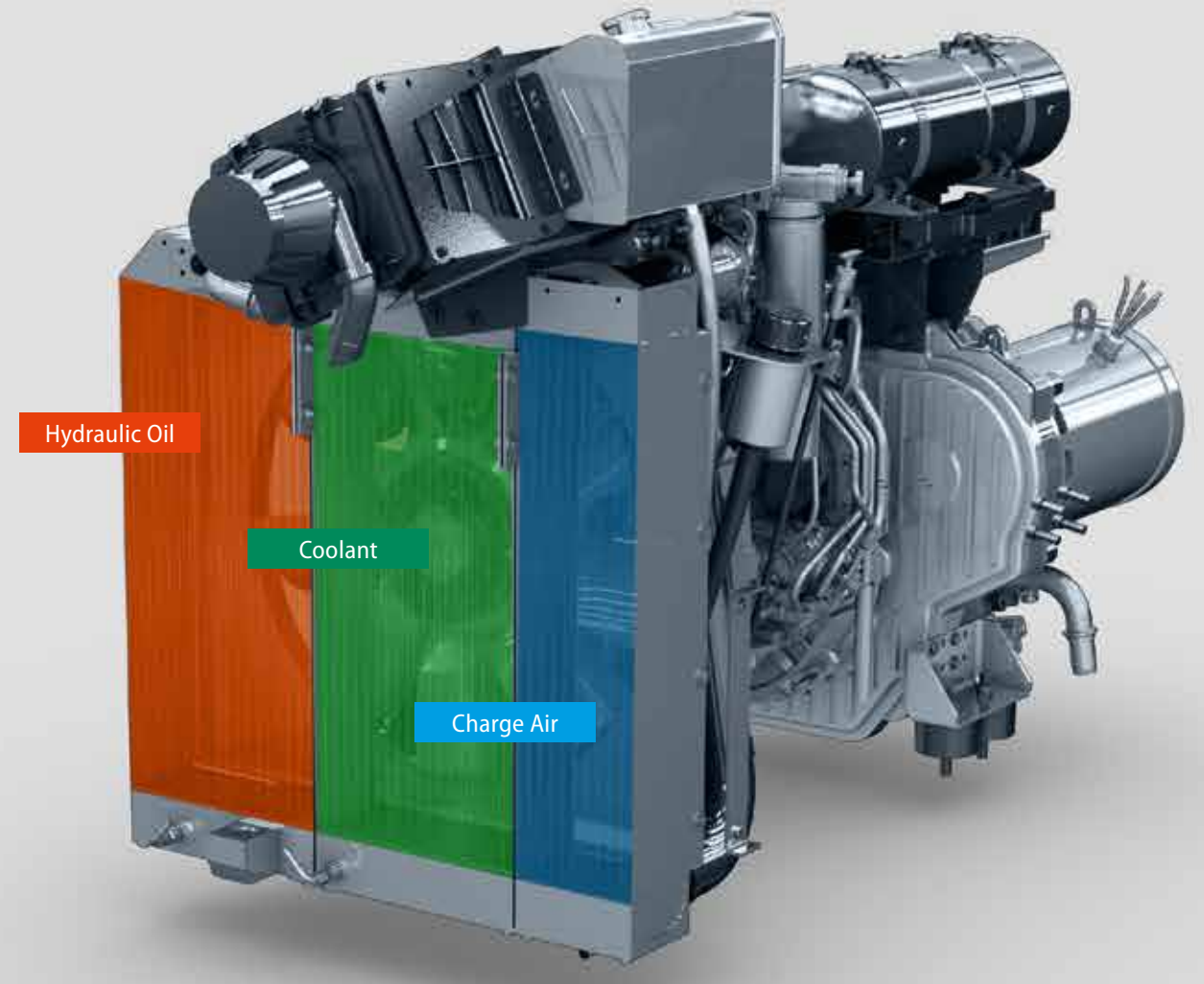
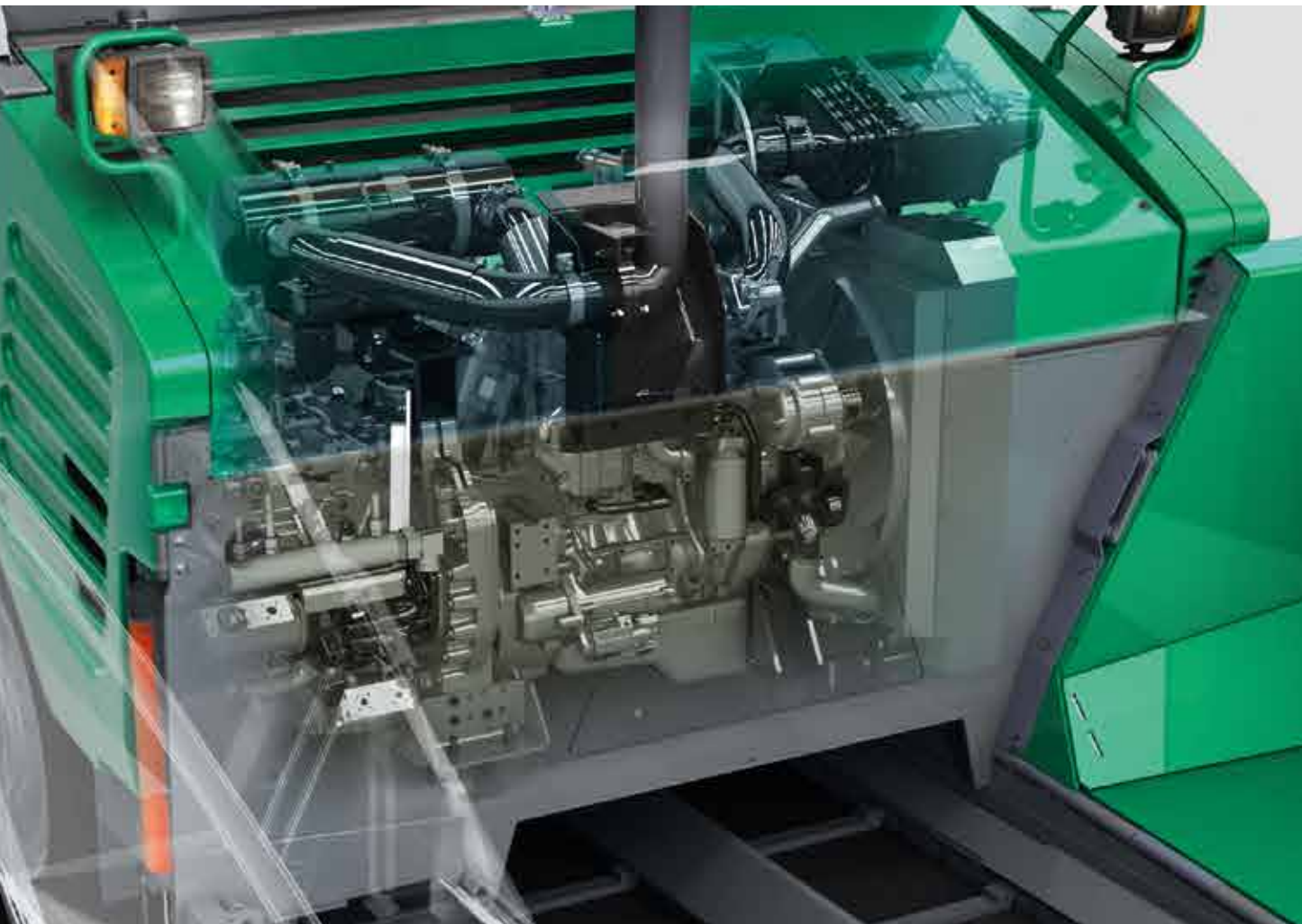

The SUPER 1603-3 is powered by a modern, liquid-cooled Cummins engine rated at 116kW.

The modern engine complies with the European emissions standard 3a, as well as the US standard EPA Tier 3.

The right temperature, however, is not important for the screed alone. In all climatic zones the world over, the large cooler assembly and innovative air routing provide for optimal temperature levels of engine coolant, hydraulic oil and charge air, while at the same time keeping noise emissions low.

With the SUPER 1603-3, technology and eco-friendliness go hand-in-hand.

» **Powerful Cummins engine** developing 116kW at just 2,000 rpm.

» **ECO mode for paver operation** with 106kW at 1,700 rpm is perfectly adequate for numerous applications. It cuts operating costs and allows superquiet operation.

» **A powerful, air-cooled generator** with direct drive ensures rapid, uniform heating of the screed. With "Dash 3" generation pavers, the generator is directly driven by the splitter gearbox and therefore maintenance-free.

» **A large cooler assembly** with innovative air routing is installed for perfect cooling of engine coolant, hydraulic oil and charge air at low noise levels.

» **A constantly high cooling capacity** provides for ideal temperatures inside the hydraulic system and top performance of all drive units even when working under full load, in all climatic zones the world over.

Mobility on Wheels



» **Maximum power transmission** thanks to separate, hydraulic drives provided for the rear wheels and one or two sets of front wheels (front-wheel drive as an option).

» **Electronic traction management** guarantees optimum tractive effort and protects the engine against overload.

» **Permanent ground contact** due to front wheels with proven, statically defined three-point support.

» **Travels rapidly on roads** (up to 20km/h) and moves quickly on the job site.

» **Thanks to its compact design**, trucking is easy. Little space required for transport cuts haulage cost.

The **small turning radius** and short overall length of the SUPER 1603-3 save manoeuvring back and forth even in tight corners. Thanks to its high tractive effort, the paver not only paves quickly, but can also be transferred quickly under its own power. This increases both productivity and efficiency.

Large Material Hopper, Easy Feed with Mix



Like all VÖGELE pavers, supply of the SUPER 1603-3 with mix is a clean, safe and swift process. Thanks to a hydraulically operated hopper front (option), the mix inside the material hopper is directed right onto the conveyors and the entirety of mix properly conveyed in front of the screed.

» **The large material hopper** holding 13t is amply dimensioned so that a sufficient quantity of mix is stored at all times. No problem to tide over difficult situations such as paving under bridges, for instance.

» **Easy feed of the paver** with mix due to low and wide hopper sides and sturdy rubber baffles.

» **Large oscillating push-rollers** for convenient and shock-free docking of feed vehicles, even in curves.



Perfect Conveyance and Spreading of Mix – A Must for Prime Pavement Quality

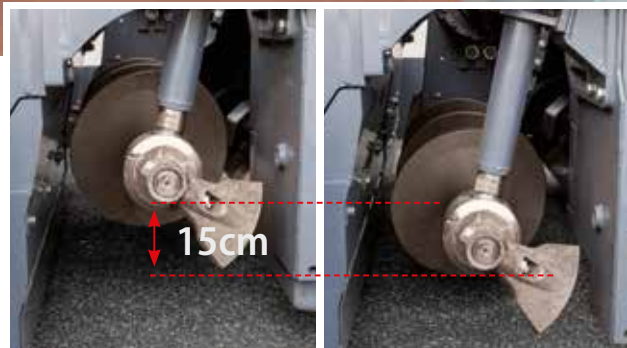

- » **Proportional control** and continuous monitoring provided for conveyors and augers guarantee a constant head of mix in front of the screed in conformity with the requirement.
- » **The height of the auger**, complete with bearing boxes and limiting plates for the auger tunnel, is hydraulically and infinitely variable by up to 15cm across the entire pave width. This results in optimal spreading of mix in front of the screed, even when paving thin layers or when the layer thickness varies.
- » **Large diameter of auger blades** (400mm) for excellent spreading of mix when paving in large widths.

Due to perfect spreading of mix, the SUPER 1603-3 provides for an optimal head of material in front of the screed in every paving situation. Powerful, separate hydraulic drives for conveyors and augers are installed achieving laydown rates up to 600t/h.

Easy Maintenance, Long Intervals Between Maintenance Services



The well-thought-out maintenance and service concept is perfectly geared to the requirements of the workshop and service staff.

» A wide engine hood and large hinged panels give convenient access to service points on the machine.

» All hydraulic pumps attached to the splitter gearbox. Their clear arrangement and easy access provides for service-friendliness at the highest level.

» Centralized lubrication system installed to automatically supply the required amounts of grease to the bearings of conveyors and augers.

» Sturdy components of highly wear-resistant materials for long service lives minimize downtime.

» A standardized service concept for all VÖGELE pavers simplifies maintenance and cuts expenditure on training.



Screed



The SUPER 1603-3 combines with the VÖGELE AB 500 Extending Screed. The AB 500 has a basic width of 2.55m and extends hydraulically to 5m. Through the addition of bolt-on extensions, the screed builds up to a maximum width of 6.5m.

» The AB 500 Extending Screed comes with a sturdy single-tube telescoping system. Working with the highest precision, it offers quick screed width control accurate to the millimetre.

» Quick-fitting aids allow easy and fast mounting of bolt-on extensions.

» The special tamper geometry of the AB 500 Extending Screed creates a flatter screed planing angle. This makes for a long service life of the screed plates and excellent results in terms of compaction and evenness.

» Homogeneous surface texture thanks to fast and uniform heating of the screed.

» Even with the paver's engine running at minimum rpm, the time required for the screed to reach its operating temperature is reduced substantially thanks to an intelligent generator management.

» When the paver functions are set to automatic, the generator management activates alternating mode for screed heating (heats the screed alternately on the left and right), a feature which is easy on the engine and reduces fuel consumption considerably.

The Screed for SUPER 1603-3



AB 500

Pave Widths

- » Infinitely variable range from 2.55m to 5m.
- » Larger widths through the addition of bolt-on extensions up to a maximum of 6.5m.

Compacting Systems

- » AB 500 TV with tamper and vibrators



AB 500 TV built up to maximum pave width

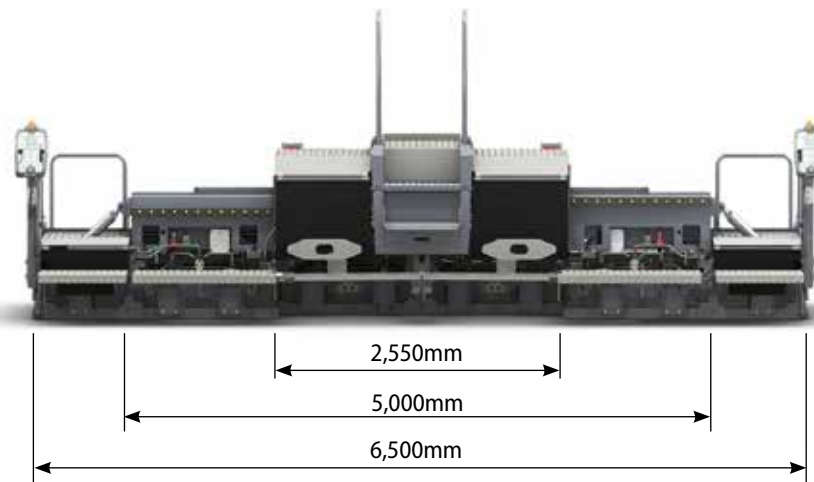

All the Facts at a Glance

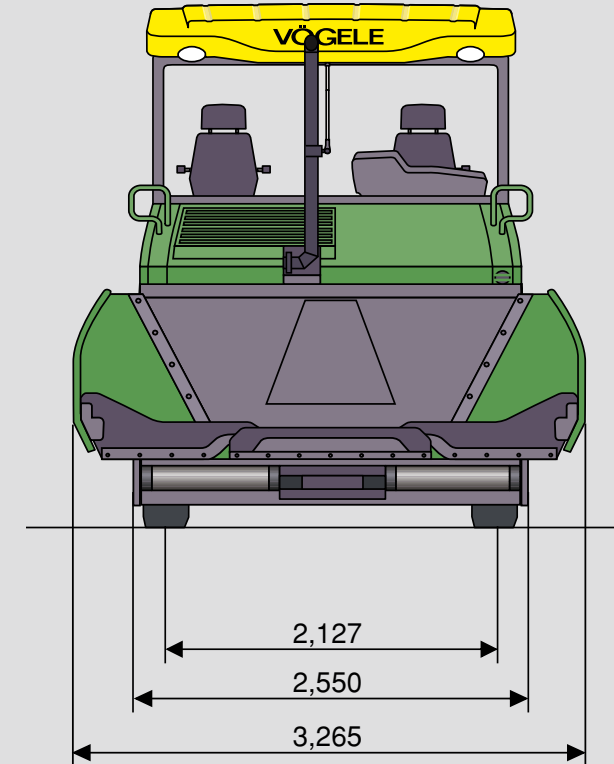
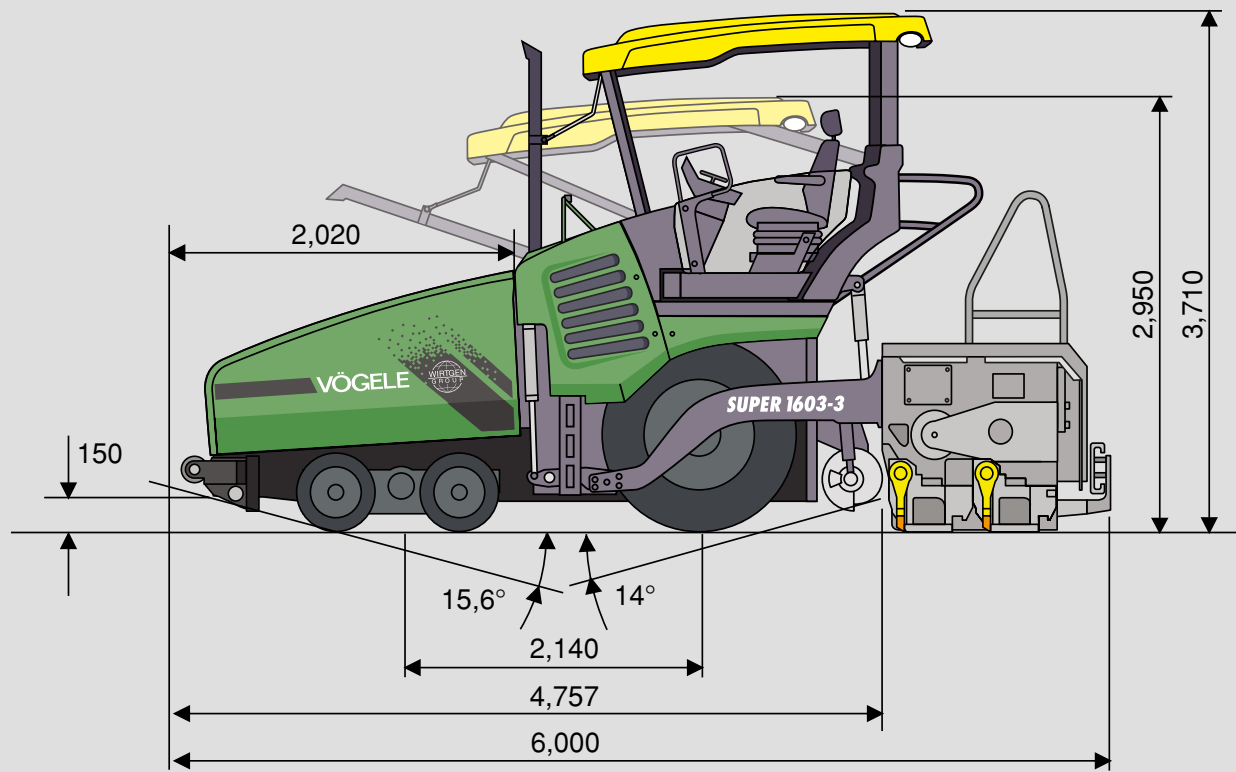

Dimensions in mm

POWER UNIT

SUPER 1603-3	
(for all countries except EU/EFTA countries / USA / Canada / Japan)	
Engine:	4-cylinder Cummins diesel engine, liquid-cooled
Type:	QSB4.5 C155
Exhaust Emissions	
Standard:	EU Stage 3a, US EPA Tier 3
Output:	Nominal: 116kW at 2,000 rpm (according to DIN)
	ECO Mode: 106kW at 1,700 rpm
Fuel Tank:	215 litres
Electrical System:	24 V

UNDERCARRIAGE

Outside Turning	
Radius:	3.5m (with "Pivot Steer")
Power Steering:	hydraulic
Service Brake:	amply-dimensioned multiple-disk brake operated by foot pedal, maintenance-free
Auxiliary Brake:	hydraulic
Parking Brake:	spring-loaded multiple-disk brake, maintenance-free

MATERIAL HOPPER

Hopper Capacity:	13t
Width:	3,265mm
Feed Height:	594mm (bottom of material hopper)
Push-Rollers:	oscillating, displaceable forwards by 150mm

CONVEYORS AND AUGERS

Conveyors:	2, with replaceable feeder bars, conveyor movement reversible for a short time
	Drive: hydraulic, separate drive provided for each conveyor
	Speed: up to 33m/min., infinitely variable (manual or automatic)

CONVEYORS AND AUGERS

Augers:	2, with replaceable auger blades, auger rotation reversible
	Diameter: 400mm
	Drive: hydraulic, separate drive provided for each auger
	Speed: up to 84 revs/min., infinitely variable (manual or automatic)
	Auger Height: infinitely variable by 15cm, hydraulic (lowest position 10cm above the ground)
Lubrication:	centralized lubrication system with electrically driven grease pump for conveyor and auger bearings

SCREED

AB 500:	basic width 2.55m, infinitely variable range 2.55m to 5m maximum width (TV) 6.5m
Screed Version:	TV
Layer Thickness:	up to 30cm
Screed Heating:	electric by heating rods
Power Supply:	three-phase A.C. generator

DIMENSIONS AND WEIGHTS

Length:	AB 500 TV: 6m (tractor unit and screed in transport position)
Weights:	Tractor unit with AB 500 screed in TV version
	- pave widths up to 5m: 17.2t
	- pave widths up to 6.5m: 18.9t

Key: T = equipped with Tamper
V = equipped with Vibrators

AB = Extending Screed

Subject to technical alterations.



© ERGOPLUS, InLine Pave, NAVITRONIC, NAVITRONIC Basic, NAVITRONIC Plus, NIVELTRONIC, NIVELTRONIC Plus, RoadScan, SprayJet, VÖGELE and VÖGELE PowerFeeder are registered Community Trademarks of JOSEPH VÖGELE AG, Ludwigshafen/Rhein, Germany. PCC is a registered German Trademark of JOSEPH VÖGELE AG, Ludwigshafen/Rhein, Germany. ERGOPLUS, NAVITRONIC Plus, NAVITRONIC BASIC, NIVELTRONIC Plus, SprayJet, VISION, VÖGELE and VÖGELE PowerFeeder are trademarks registered in the US Patent and Trademark Office to JOSEPH VÖGELE AG, Ludwigshafen/Rhein, Germany. Legally binding claims cannot be derived from written information or pictures contained in this brochure. Pictures may include optional extras. We reserve the right of technical or design alterations.

JOSEPH VÖGELE AG

Joseph-Vögele-Str. 1
67075 Ludwigshafen · Germany
marketing@voegele.info

Telephone: +49 (0)621 8105 0
Fax: +49 (0)621 8105 461
www.voegele.info