

Technical information

SUPER 1800-3(i)



Tracked paver SUPER 1800-3(i)

Universal Class

TECHNICAL HIGHLIGHTS

- > Maximum pave width 10 m
- > Maximum laydown rate 700 t/h
- > Transport width 2.55 m
- > Engine output: 127/129 kW at 2,000 rpm

SUPER 1800-3(i) - top of its class

The SUPER 1800-3(i), the most powerful tracked paver in its performance class, covers an incredibly wide range of applications. With a maximum pave width of 10 m and a machine length of just 6.04 m, the VÖGELE paver handles motorway projects just as well as tight roundabouts.

The innovative, easy-to-understand ErgoPlus 3 operating concept creates a work environment with all the ergonomic and practical advantages a machine operator could possibly want.



TECHNICAL DATA	SUPER 1800-3i	SUPER 1800-3
Power unit		
	for EU/EFTA countries/USA/Canada/Japan	for all other countries
Engine	liquid-cooled 6-cylinder diesel engine	
> Version	Cummins	
> Manufacturer	Cummins	
> Type	B6.7-C173	QSB6.7-C170
Output		
> Nominal	129 kW at 2,000 rpm	127 kW at 2,000 rpm
> ECO mode	129 kW at 1,700 rpm	116 kW at 1,700 rpm
Emissions information		
> Exhaust emissions standards	EU Stage V, US EPA Tier 4f	EU Stage 3a, US EPA Tier 3
> Exhaust gas after-treatment	DOC, DPF, SCR	
> Guaranteed sound power level	L _{WA} = 108 dB(A) (2000/14/EG, EN ISO 3744; EN 500-6)	
> Sound pressure level at the operator's stations	L _{PA} ≤ 85 dB(A) (EN ISO 11201; EN 500-6)	
Fuel tank	300 litres	
Undercarriage		
Crawler tracks		
> Version	with rubber pads	
> Ground contact	2,830 x 305 mm	
> Track tension adjuster	spring assembly	
> Lubrication of track rollers	lifetime	
Traction drive	separate hydraulic drive and electronic control provided for each crawler track	
Speeds		
> Paving	up to 24 m/min., infinitely variable	
> Travel	up to 4.5 km/h, infinitely variable	
Material hopper		
Hopper capacity	13 t	
Width	3,265 mm	
Feed height	590 mm (centre of material hopper)	
Push-rollers		
> Standard	oscillating	
Position	can be displaced forwards by 75 mm or 150 mm	
> Option	sprung (PaveDock)	

Conveyors and augers

Conveyors

> Version	2, with replaceable feeder bars, conveyor movement reversible for a short time
> Drive	separate hydraulic drive provided for each conveyor
> Speed	up to 34 m/min., infinitely variable (manual or automatic)

Augers

> Version	2, with exchangeable auger blades, auger rotation reversible
> Diameter	400 mm
> Drive	separate hydraulic drive provided for each auger
> Speed	up to 84 rpm, infinitely variable (manual or automatic)
> Height	infinitely variable by 15 cm, hydraulic, lowest position 10 cm above the ground

Lubrication automatic centralized lubrication system with electrically driven grease pump

Screed options	AB 500	AB 600	SB 300	SB 300 HD
Basic width	2.55 m to 5 m	3 m to 6 m	3 m	3 m
Maximum width (TV/TP1)	8.5 m	9 m	10 m	8 m
Compacting systems	TV, TP1, TP2, TP2 Plus	TV, TP1, TP2, TP2 Plus	TV, TP1, TP2	TV
Layer thickness	up to 30 cm			
Screed heating				
> Version	electric by heating rods*			
> Power supply	three-phase AC generator			

Dimensions (transport) and weights

Length

> Version	tractor unit and screed
> AB 500/600	TV: 6.04 m / TP1, TP2, TP2 Plus: 6.17 m
> SB 300	TV, TP1, TP2: 6.1 m
> SB 300 HD	TV: 6.1 m

Weights

> Version	tractor unit and screed
> AB 500 TV	pave widths up to 5 m: 19,700 kg / pave widths up to 8.5 m: 25,450 kg

Key: DOC = Diesel Oxidation Catalyst, DPF = Diesel Particulate Filter, SCR = Selective Catalytic Reduction, AB = Extending Screed, SB = Fixed-Width Screed, HD = Heavy-Duty, TV = with tamper and vibrators, TP1 = with tamper and 1 pressure bar, TP2 = with tamper and 2 pressure bars, TP2 Plus = with special tamper, 2 pressure bars and additional weights, * not for SB 300 HD

SIDE AND FRONT VIEW

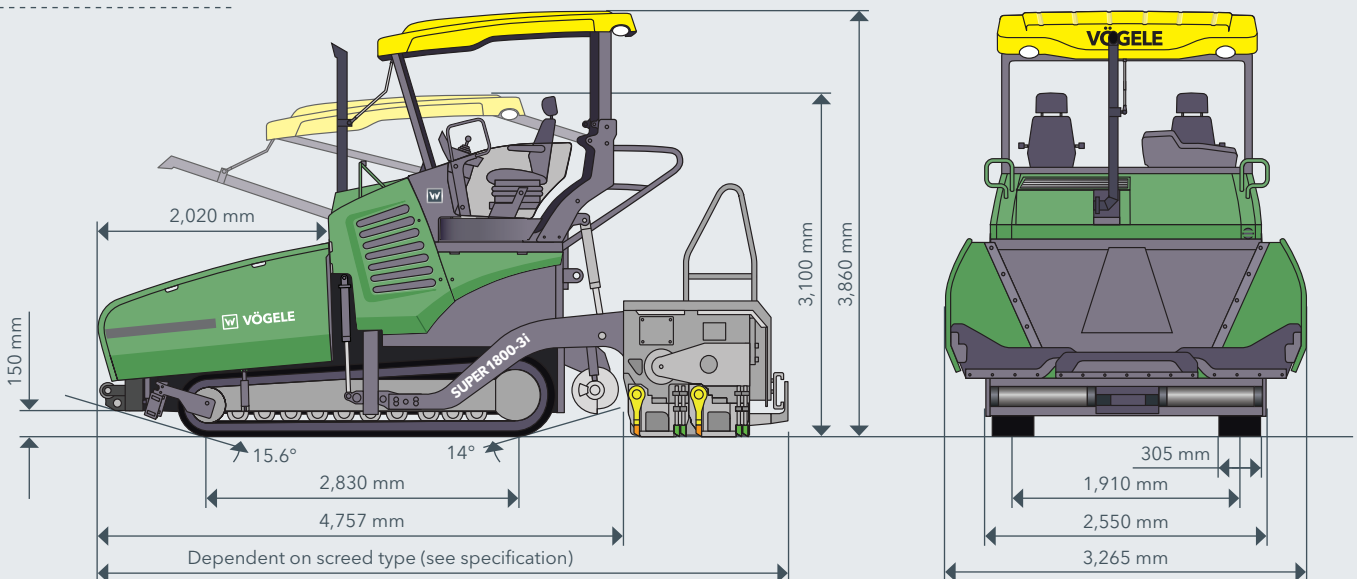

THE HIGHLIGHTS OF THE SUPER 1800-3(i)

- > Tracked Universal Class paver with a large range of applications and pave widths up to 10 m
- > Powerful and economical drive concept, even when operating at full load in any climate zone
- > The VÖGELE EcoPlus low-emissions package significantly reduces fuel consumption and noise levels
- > Optimum feeding with mix thanks to the large material hopper, PaveDock sprung push-rollers and PaveDock Assistant communication system
- > ErgoPlus 3 operating system with numerous convenient and automatic functions
- > All screeds can be used with high compaction technology

FEATURES	SUPER 1800-3i	SUPER 1800-3
> Simple, ergonomic ErgoPlus 3 operating concept	■	■
> Powerful oil-cooled generator	■	■
> Large receiving hopper holding 13 tonnes	■	■
> WITOS FleetView telematics system	■	■
> VÖGELE EcoPlus low-emissions package	■	□
> Windscreen with windscreen wipers	□	□
> Ergonomic heated driver's seats	□	□
> AutoSet Plus for simple repositioning and saving of paving programs	□	□
> LED light balloon for use at night	□	□
> Hydraulic hopper front	□	□
> Sonic sensor to control augers	□	□
> PaveDock sprung push-rollers	□	□
> PaveDock Assistant communication system	□	□
> Niveltronic Plus System for Automated Grade and Slope Control	□	□
> Ventilation system	□	□
> VÖGELE RoadScan comprehensive asphalt temperature measuring system	□	□
> WITOS Paving Docu records paver and paving data	□	□
> WITOS Paving Plus process management solution	□	□

This list is just an extract of the scope of supply.
Standard features and options may differ by sales region.

■ Standard feature □ Option

JOSEPH VÖGELE AG

Joseph-Vögele-Str. 1
67075 Ludwigshafen
Germany

T: +49 621 8105-0
F: +49 621 8105-461
M: marketing@voegele.info

▶ www.voegele.info

