



gru\_truck cranes

www.pesci-cranes.com



**PESCI**

**SE 108**

SC version

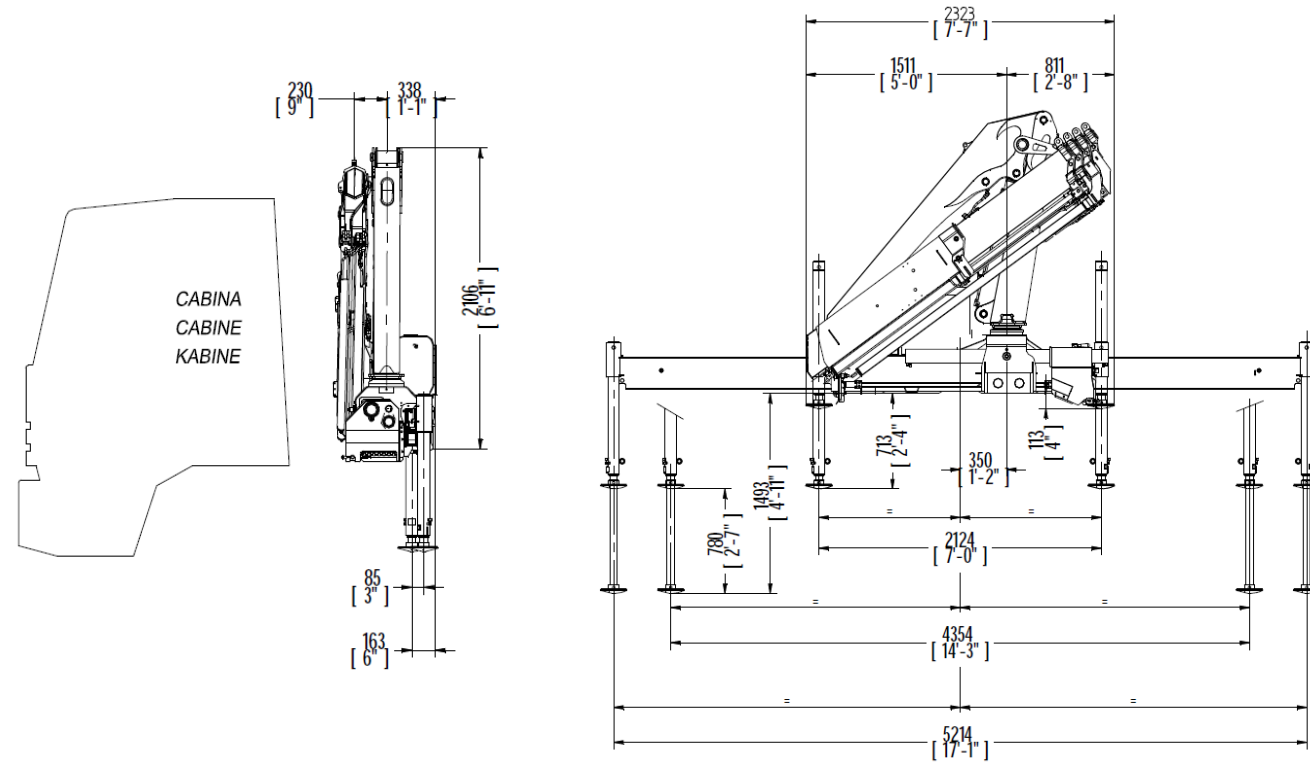

gru\_truck cranes



Costruttore C.P.S. srl Via Emilia levante, 281 48014 Castel Bolognese (RA) - ITALIA  
Tel. +39 0546 653833 Fax. +39 (0)546 656205 E-Mail info@pesci-cranes.com www.pesci-cranes.com

- > Scheda tecnica
- > Fiche technique
- > Technische daten

- > Technical features
- > Ficha tecnica
- > Folha de dados

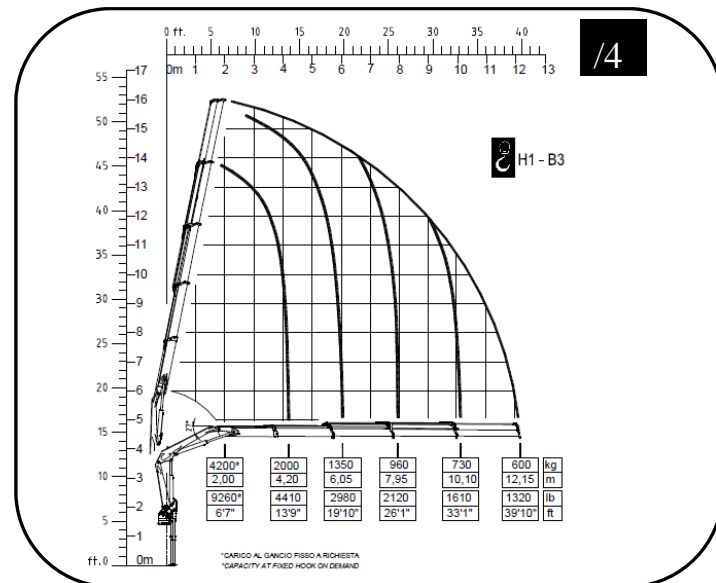
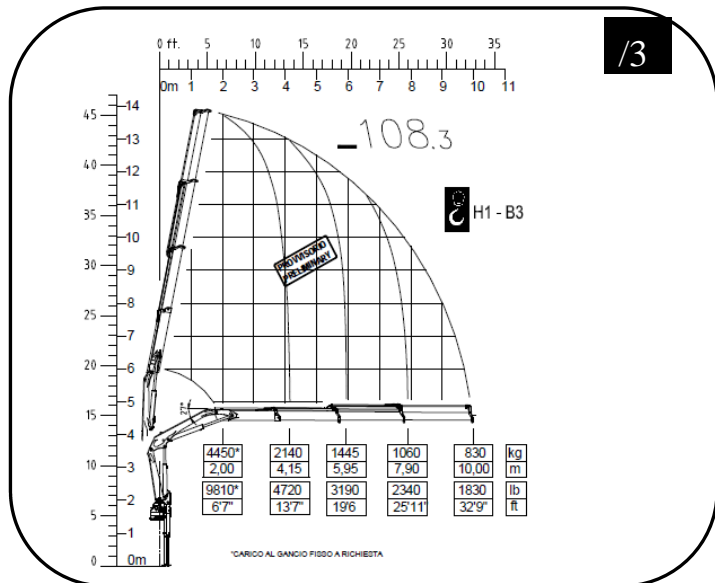
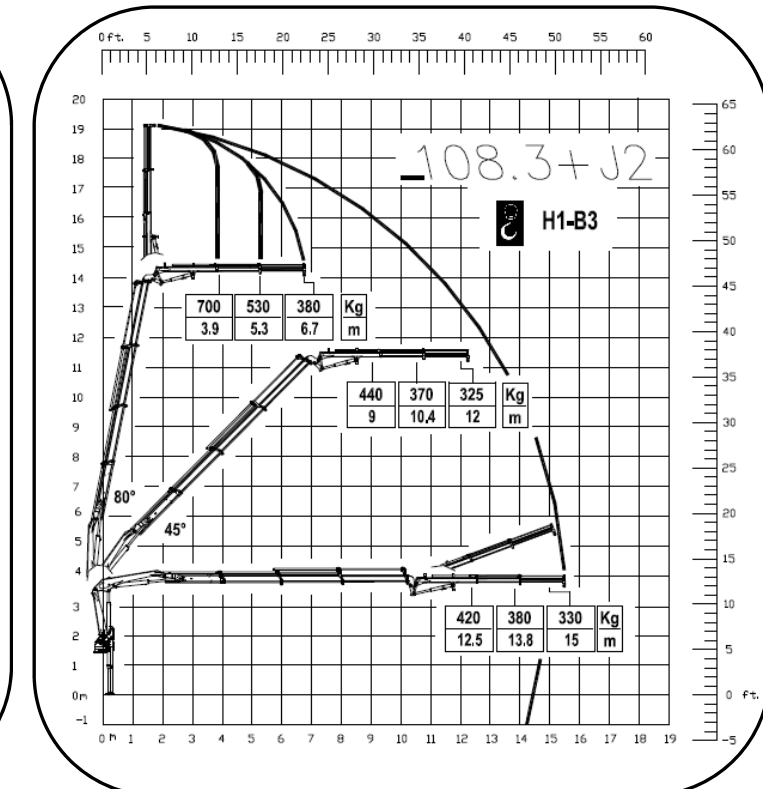
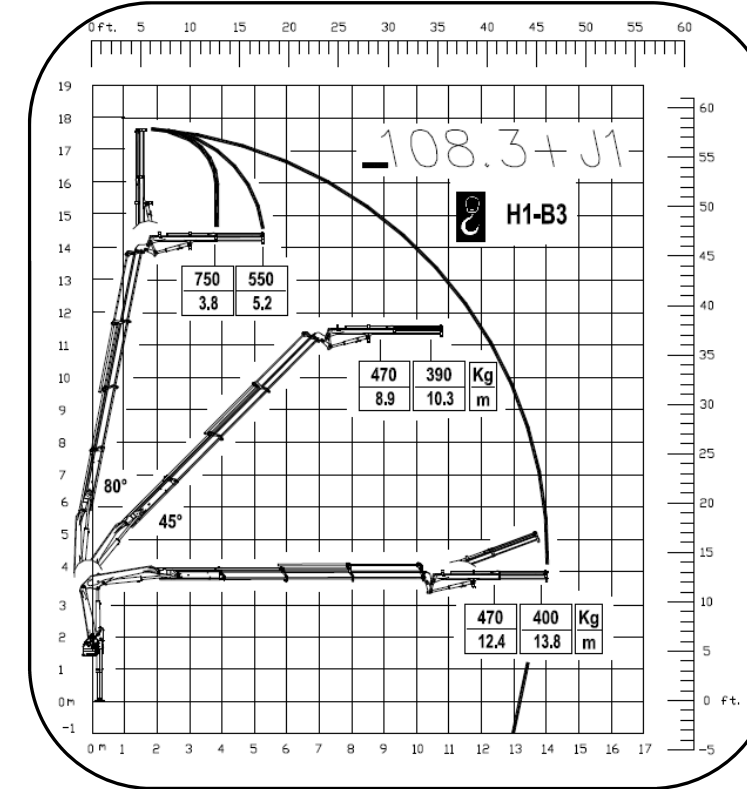
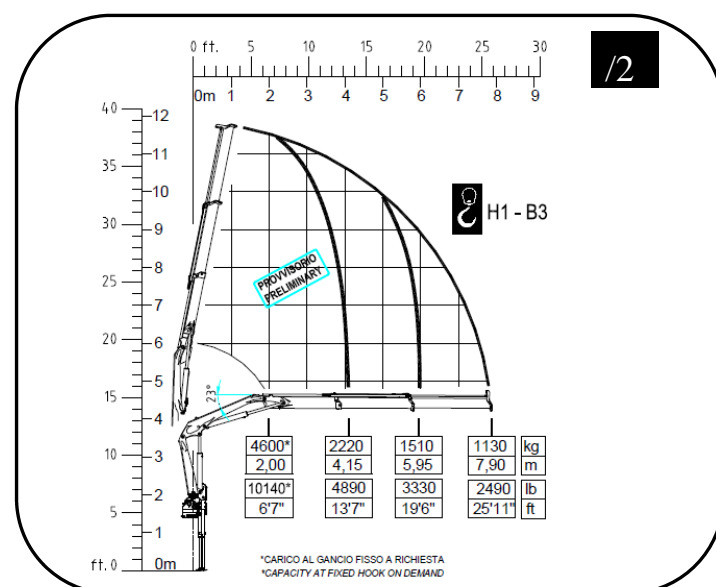
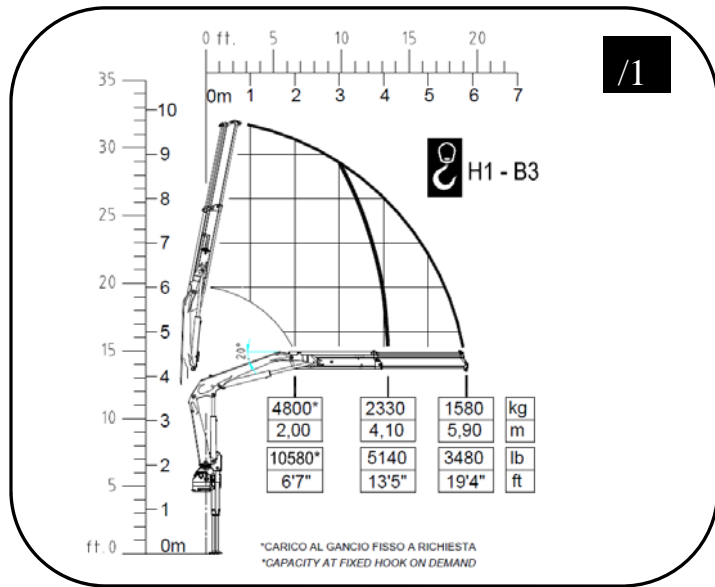

Std version

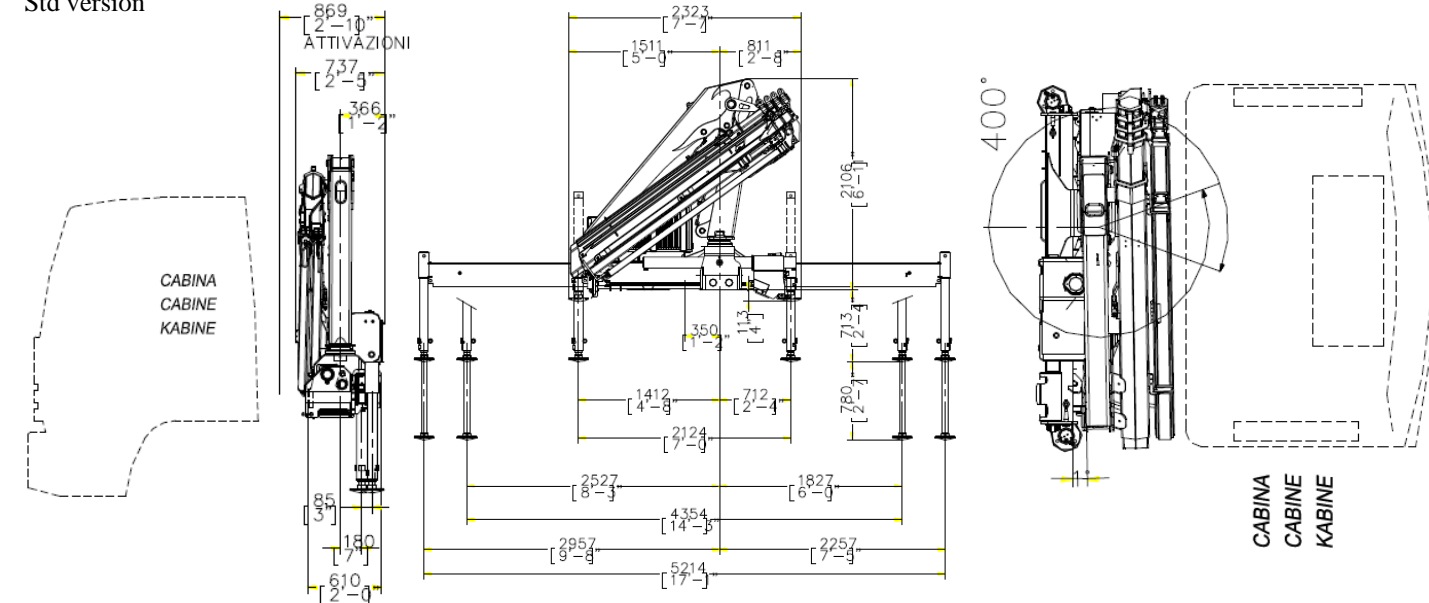

1 2 3 4 1 2 3 4

- MOMENTO MAX SOLLEVAMENTO - HUBMOMENT - COUPLE DE LEVAGE - MOMENTO - MOMENTO - MAX LIFTING MOMENT	93.7 kN.m	90 kN.m	87 kN.m	82 kN.m	- PORTATA POMPA OTTIMALE - FÖRDERMENGE DER PUMPE - PORTÉE DE LA POMPE - CAUDAL DE LA BOMBA - CAUDAL DA BOMBA - RECOMMENDED PUMP DELIVERY	25 l/m	25 l/m	25 l/m	25 l/m
- ANGOLO DI ROTAZIONE - SCHWENKBEREICH - ROTATION - GIRO - ROTAÇÃO - SLEWING ANGLE	400°	400°	400°	400°	- CAPACITÀ SERBATOIO OLIO - FASSUNGSVERMÖGEN DEL ÖLBEHALTERS - CAPACITÉ RÉSERVOIR HUILE - CAPACIDAD DEL DEPOSITO DE ACEITE I - CAPACIDAD DO DEPOSITO DE OLEO - OIL TANK CAPACITY	50 l	50 l	50 l	50 l
- COPPIA MAX ROTAZIONE - MAX SCHWENKMOMENT - COUPLE MAXI. DE ROTATION - POTENCIA MÁXIMA DE GIRO - BINARIO MÁXIMO DE ROTAÇÃO - SLEWING TORQUE	1200 daN.m	1200 daN.m	1200 daN.m	1200 daN.m	- VEICOLO MIN. P.T.T. - LKW MIN. G.G.W. - CAMION MIN. P.T.A.C. - CAMION PESO MIN. P.T.T. - P.B. MIN CAMION - TRUCK MIN. G.V.W	12 t	12 t	12 t	12 t
- PRESSIONE MAX LAVORO - DRUCK - PRESSION - PRESSIÓN - PRESSÃO - MAX WORKING PRESSURE	280 bar	280 bar	280 bar	280 bar	- PESO GRU - GEWICHT - POIDS - PESO - PESO - CRANE WEIGHT	1000 kg	1100 kg	1190 Kg 2620 Lbs	1260 kg

SC version

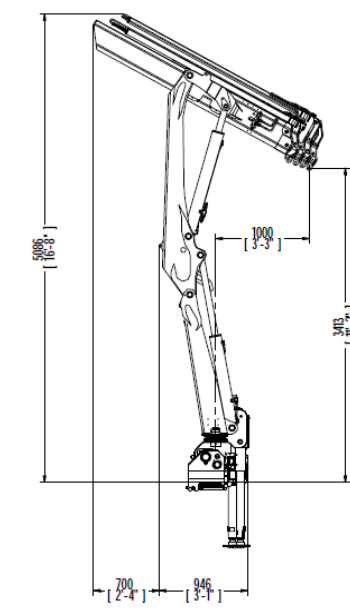
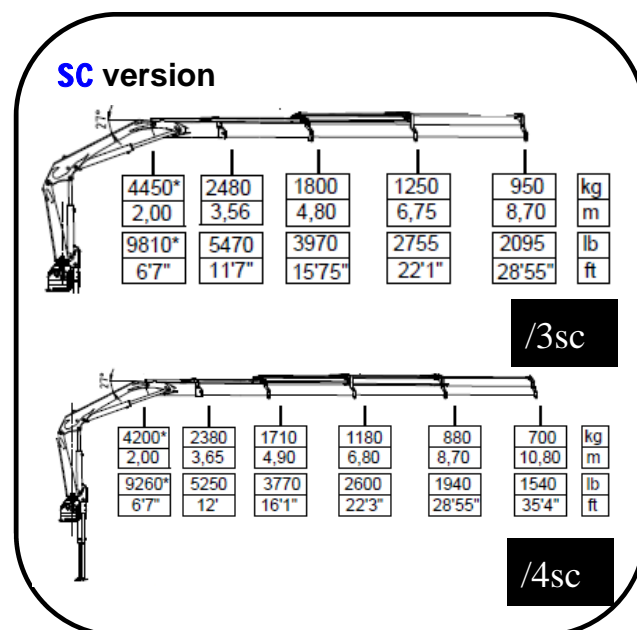

Modelli SC

La versione SC (Secondario Corto) è un modello di gru equipaggiato con un braccio secondario più corto di quello standard che permette di caricare più agevolmente vicino alla colonna.

SC Models

The SC version (Short Secondary Boom) is a crane equipped with a secondary boom shorter than standard which allows to load more smoothly next to the column.

I dati e le descrizioni del presente catalogo sono forniti a titolo indicativo e non sono vincolanti. PESCI si riserva il diritto di modificarli senza preavviso. Technical features are not binding. PESCI reserves itself the right to any modification without notice.