

Stereoloaders®

L 507 - L 514

Stereo Stereo

Tipping load, articulated: 3,712 kg – 5,680 kg



**New
Generation**

LIEBHERR

L 507 Stereo

Tipping load, articulated: 3,712 kg
Bucket capacity: 0.9 m³
Operating weight: 5,470 kg
Engine output: 50 kW

L 509 Stereo

Tipping load, articulated: 4,430 kg
Bucket capacity: 1.2 m³
Operating weight: 6,390 kg
Engine output: 54 kW

L 514 Stereo

Tipping load, articulated: 5,680 kg
Bucket capacity: 1.5 m³
Operating weight: 8,350 kg
Engine output: 77 kW



Performance

Liebherr Stereoloaders® are flexible 'power all-rounders'. Their unique steering system gives them exceptional maneuverability and with their tight articulation angle of only 30 degrees they can move exceptionally heavy payloads whilst maintaining maximum stability and tipping safety.

Economy

The Stereoloaders® produce palpable benefits. They are enormously flexible and permanently economical to use, offering exceptional value for money. The improved cooling system actively reduces both fuel consumption and maintenance costs. Two **Speeder** version models are available for jobs where speed counts.

Reliability

The highly successful "Stereo" concept has undergone continuous development since its launch in 1994. The machines have proven themselves in the toughest imaginable conditions. Water-cooled 4-cylinder diesel engines are used to provide a powerful, reliable, source of power.

Comfort

A unique Liebherr feature is that the oscillating center pivot coupled with the pendulum axle reduces the maximum cab tilt angle when crossing rough surfaces by half, thus ensuring maximum safety and comfort. The comfortable operator's cab has safe, convenient and extremely wide access even when the loader is fully articulated. Ergonomic controls allow the operator to work with minimal fatigue whilst also enhancing his safety.





Stereoloader®
competing



Unique steering system

- The Stereoloaders® steering geometry combines a centre pivot with a steered rear axle, for maximum operating efficiency even in the most confined spaces.
- Amazingly tight turning circle: up to 20% smaller than comparable conventional steered wheel loaders.



Performance

Liebherr Stereoloaders® are flexible 'power all-rounders'. Their unique steering system gives them exceptional maneuverability and with their tight articulation angle of only 30 degrees they can move exceptionally heavy payloads whilst maintaining maximum stability and tipping safety.

Outstanding manoeuvrability

20% more flexibility

The turning circle of the Stereoloaders®, measured at the outer extremity of the working equipment, is as much as 20% less than vehicles with centre-pivot steering only. This can provide as much as 50 cm more clearance to guarantee maximum working efficiency.

Outstanding stability

Maximum tipping safety and high payloads

The Stereoloader® steering geometry combines a centre pivot with a steered rear axle for a reduced articulation angle of just 30° (compared to conventional models with 40°) enabling it to carry comparatively heavier loads - more payload with less operating weight. At the same time it means the best stability and tipping safety in this class.

Suitable for universal use

Designed for rugged use

Their sturdy construction and solid components make the Stereoloaders® ideal for rugged use. The powerful hydraulic system enables them to work at maximum speed.

Flexibility with a wide array of attachments

The wide array of attachments and special equipment such as sweeping machines, snow clearing machines, special buckets and the range of options, particularly for industrial applications, make the Stereoloader® extremely versatile and flexible in use. The machines can be used for a very wide range of applications to suit the specific requirements of the job in hand.

Existing Z-bar working equipment from the previous wheel loader generation can continue to be used with the new, improved Z-bar linkage.

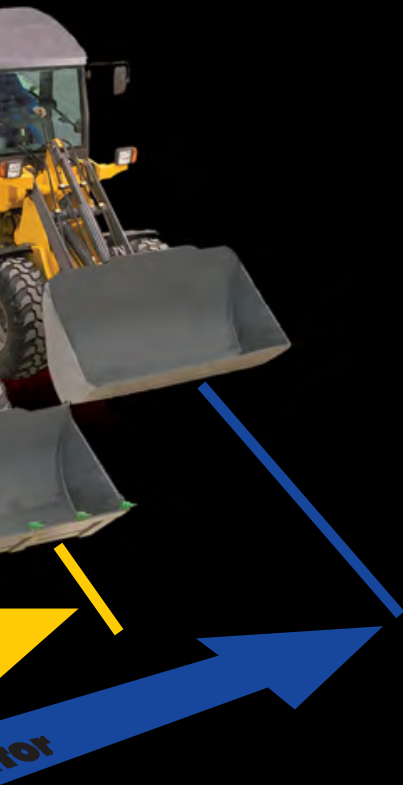

Excellent stability and tipping safety

- High payload with low operating weight and the highest possible stability are the results of the unique stereo steering system with a maximum articulation angle of 30°.
- Unblocked view of the entire working and manoeuvring area, for a maximum of safety.



A true all-purpose machine

- With a big selection of working equipment and attachments, the Stereoloaders® are high-performance 'jacks of all trades' and profitable to operate.
- The stable construction and solid design of the components make the Stereoloader® durable and efficient - even in rugged conditions.



Controlled cooling

- Optimised cooling airflow – an invaluable benefit, particularly in very dusty working conditions.
- Cooling air is drawn in from the 'cleanest' zone directly behind the rear window.



Ideal for tasks involving longer road journeys: the Speeder

- The L 507 and L 509 are available in **Speeder** versions as an option, with a top speed of 30 km/h. This makes them ideal for jobs involving a high proportion of travelling between the work areas.

Economy

The Stereoloaders® produce palpable benefits. They are enormously flexible and permanently economical to use whilst also offering exceptional value for money. The improved cooling system permanently reduces both fuel consumption and maintenance costs. Two **Speeder** version models are available for jobs where speed counts.

Low operating costs

Demand-controlled cooling

The optimised cooling system for the diesel engine and the hydraulic system supplies precisely the power required to the cooling fan. The improved cooling system also cuts maintenance and cleaning costs.

“Speeder”

Higher top speed

The L 507**Stereo** and L 509**Stereo** are available in **Speeder** versions as an option. They then have a top speed of 30 km/h – ideal for rapid journeys between working sites and fast load handling movements.

Adaptable equipment

Optimised kinematics

The optimized Z-bar linkage, with its generous dumping height and outreach, has a performance that could formerly only be obtained with two different systems (parallel and Z-bar linkages). The dimensions for connecting the previous and latest Z-bar linkages are identical, so that equipment is fully interchangeable and older items can still be used.

Simple maintenance

Excellent access

When the compact engine cover is opened, all maintenance points can be reached easily and safely from the ground. All the check points and fluid levels are clearly visible and easy to access.



Optimised kinematics

- The optimised Z-bar linkage with its generous dumping height and vertical clearance satisfies the highest performance standards applicable to work on construction sites and in industry.
- The mounting points have not changed, so that existing Z-bar equipment can be attached to the new Stereoloaders® without difficulty.
- Standard equipment for the powerful Z-bar linkage is an integral hydraulic quick-hitch.



Easy, safe access

- The engine compartment has a compact hinge-up cover which gives unobstructed access to all maintenance points.



Diesel engine

- The familiar standards of quality and reliability are shared by new 4-cylinder water-cooled diesel engines.
- A reliable, powerful driveline.



Reliability

The Liebherr Stereoloaders® are a combination of mature, well-proven technology and innovations designed to boost performance still further. The highly successful "Stereo" concept has undergone continuous development since its launch in 1994. The machines have proven themselves in the toughest imaginable conditions. Water-cooled 4-cylinder diesel engines are used to provide a powerful, reliable, source of power.

All-round safety

Excellent all-round visibility

The high seat position in the cab provides the operator with an excellent view in all directions so that he can see the entire working area. Dangerous situations for personnel and objects in the working area, for the operator and for the wheel loader can be identified faster and thus averted.

Quality down to the last detail

Cooling and airflow system

Further evidence of Liebherr's well thought-out design principles: the radiator is located directly behind the cab, so that fresh air can be drawn in from a relatively clean zone. This improves cooling-system performance in very dusty conditions and greatly reduces the amount of maintenance work and cleaning needed.

Diesel engine

The water-cooled 4-cylinder diesel engines reach the same high standards of quality and reliability that are a feature of all Liebherr products, and drive the Stereoloaders® safely and powerfully.

Strong linkage

Thick-walled bearing bushings together with the solid design of the lift arm ensure long, trouble-free operating life.

Hydraulic quick-hitch

The quick-hitch is compatible with Liebherr Compact Loaders and most conventional attachments. All its parts are made from high-grade materials.

Technology you can trust

Suitable for all jobs

The Stereoloaders® will operate to the same excellent standards of reliability as the previous models. They are particularly durable, even in rugged conditions.



Robust operating linkage

- The linkage is rated for fast, powerful work cycles and copes easily with the toughest conditions every likely to be encountered in day-to-day work.



A well-proven basis for higher performance

- Unceasing development work has gone into the "Stereo concept" to ensure high quality and reliability in every detail.



Above: Cabin L 507 and L 509.

Left: Display L 514.

- The ergonomically correct layout of all the controls makes precision handling of the wheel loader easy.
- Clearly arranged displays with visual and acoustic warning devices ensure high operating safety.



Easy access

- A safe, convenient and extremely wide access to the operator's cab ensures maximum safety and comfort for the operator even when the Stereoloader® is at maximum articulation.





Comfort

A unique Liebherr feature is that the oscillating center pivot coupled with the pendulum axle reduces the maximum cab tilt angle when crossing rough surfaces by half, thus ensuring maximum safety and comfort. The comfortable operator's cab has safe, convenient and extremely wide access even when the loader is fully articulated. Ergonomic controls allow the operator to work with minimal fatigue whilst also enhancing his safety.

Perfection in cab design

Maximum safety for personnel, the machine and the load

All the instruments and displays are correctly positioned for easy use. This enables the operator to work particularly productively and safely. From his seat the operator also has an excellent view of the working and maneuvering areas and is therefore assured of maximum safety for himself, other people and objects near the machine.

Minimal fatigue and safe working

Effective noise reduction

Optimised cab design has also reduced the noise level inside the cab compared with the previous models; it is now at the impressively low figure of 70 decibels. This provides the operator with perfect conditions to concentrate on his work and be more productive.

Stable and safe performance

In the center pivot area, shock-absorbing elements minimize vibration from travel movement and help to prevent it from reaching the operator, making the Stereoloaders® smoother and more stable when cornering. The long wheelbase contributes to the loader's consistently good dynamic performance as well. This helps the operator to concentrate better and thus enhances his own safety and that of the area around where he is working. Moreover the oscillating center pivot lowers the center of gravity when driving on gradients thus enhancing the machine's stability and tipping safety.

Precise, low-effort control

The Liebherr single-lever principle

A single 'joystick' lever controls all the loader's working movements accurately and with the necessary sensitivity for exact, safe vehicle and load positioning. One hand can remain on the steering wheel at all times.



Unique oscillating system

- The combination of oscillating centre pivot and swing axles reduces the maximum cab tilt angle of 12° by half: For unique handling and excellent stability and tipping safety.

- Initial position
- Lateral slope angle
- Stereolader®
- Conventional systems



A practical option

- A large, lockable toolbox can be supplied as an optional extra for the access area. This is a convenient place to keep items that may be needed every day, such as tools, lashing tackle or a grease gun.



Safety in and around the machine

Cargo safety

- + Optimal visibility of the equipment during loading and unloading
- + Fast, safe positioning of the load
- + Safe transport of the load, even on uneven terrain

- ✓ High seat position in the cab
- ✓ Stereo system: combination of oscillating center pivot and steered rear axle

Personnel safety

- + Clear all-round visibility
- + Clear visibility of equipment and load
- ✓ High seat position in the cab
- ✓ Optimal layout of all mirrors

Stability and tipping safety

- + Maximum stability in all site situations
- + Maximum tipping safety even when loaded and fully articulated
- + High payloads
- ✓ Stereo steering: articulation angle just 30°
- ✓ Stereo system: oscillating center pivot combined with steered rear axle
- ✓ Excellent ratio between weight and tipping load



Operating safety

- + The operator's concentration is enhanced
- + Easy start-up
- ✓ Ergonomic layout of the controls
- ✓ Stereo system reduces the lateral cab tilt by half
- ✓ All maintenance and check points are easily accessible by walking around the machine

Safe and versatile usage

- + Flexible and efficient in use - even in constricted spaces
- + Maximum working speed, minimum cycle times
- + Durable and powerful - particularly for rugged jobs
- + Versatile
- ✓ Tight turning circle with the stereo system combination of oscillating center pivot and steered rear axle
- ✓ Sturdy machine construction and solidly designed components
- ✓ Optional Speeder version (30 km/h)
- ✓ Wide range of options for demanding applications

Technical Data

L 507 - L 509



Engine L 507 L 509

Diesel engine	4TNV98-CR	4TNV98T-CR
Design	Water-cooled Diesel suction engine	Turbocharged water-cooled Diesel engine
Number of cylinders	4	4
Fuel injection process	Common Rail direct injection	
Max. output according to DIN/ISO 3046	54 kW at RPM 2,400	54 kW at RPM 2,400
Max. torque	235 Nm at RPM 1,560	279 Nm at RPM 1,560
Displacement	3.32 litres	3.32 litres
Air cleaner	Dry type with main and safety element	
Electrical system		
Operating voltage	V 12	12
Capacity	Ah 100	100
Alternator	V/A 12/80	12/80
Starter motor	V/kW 12/3	12/3

The exhaust emissions are below the limits in stage IIIB / final Tier 4.

L 507

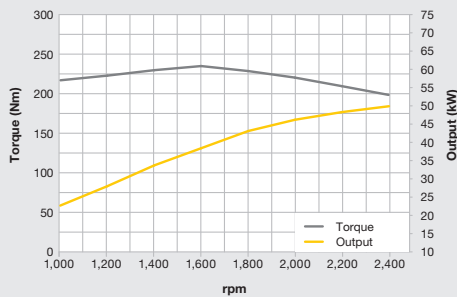

L 509

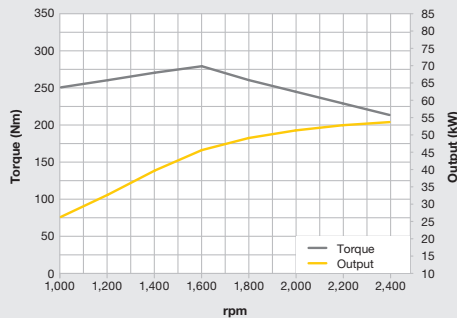

Axles

Design	Four-wheel drive
Front axle	Rigidly mounted planetary-hub axle
Rear axle	Centre pivot, with 5° oscillating angle to each side
Differentials	Automatic limited-slip differentials with 45% locking action in both axles
Reduction gear	Planetary final drive in wheel hubs
Track width	1,486 mm (L 507) 1,660 mm (L 509)
Design Speeder	Four-wheel drive
Front axle	Rigidly mounted planetary-hub axle
Rear axle	Centre pivot, with 5° oscillating angle to each side
Differentials	100% differential lock in front axle, manually engaged
Reduction gear	Planetary final drive in wheel hubs
Track width	1,486 mm (L 507 Speeder) 1,660 mm (L 509 Speeder)



Brakes

Service brake	Wear-free service brake due to hydrostatic travel drive, applied to all four wheels and additional drum brake system
Parking brake	Mechanically operated drum brake
Brake system Speeder	
Service brake	Dual-circuit brake system, drum brake and wet multi-disc brake on front axle
Parking brake	"Negative brake system" on front axle acting on the wet multi-disc brakes

The braking system meets the requirements of the EC guidelines 71/320.



Travel Drive

Stepless hydrostatic travel drive	
Design	Wash plate type variable flow pump and a variable axial piston motor in a closed loop circuit
Filtering system	Suction return line filter for closed circuit
Control	Control of travel drive with travel and combined inching pedal. The inching pedal permits continuously variable adjustment of crowding and tractive force to match ground and operating conditions. The Liebherr joystick is used to control forward and reverse travel
Travel speed range (forward and reverse)	Speed range 1 0 - 6.0 km/h Speed range 2 0 - 20.0 km/h Speeder (L 507 and L 509) 0 - 30.0 km/h

The quoted speeds apply with the tyres that are standard equipment on the loader



Steering

Design	"Stereo" steering system, hydraulic servo power steering. Central oscillating frame articulation in combination with rear-axle pivot steering, and damper element
Angle of articulation	30° to each side
Angle of oscillation - Centre-pivot steering	5° to each side
Max. pressure	180 bar



Attachment Hydraulics

Design	Gear pump to supply the hydraulic and steering systems (via priority valve)
Filtering	Suction return line filter in the hydraulic reservoir
Control	"Liebherr Joystick" with hydraulic servo control
Lift circuit	Lifting, neutral, lowering and float positions controlled by Liebherr joystick with detent; automatic lifting-limit circuit
Tilt circuit	Tilt back, neutral, dump additional functions are activated by an optional "convenient control system"
Additional hydraulics	3. control circuit is optional equipment
Max. flow	L 507 79 l/min L 509 93
Max. pressure	bar 230 210



Attachment

Geometry	Powerful Z-pattern linkage with standard hydraulic quick-release coupling
Bearings	lathe-turned thick-walled bushings with lubricating grooves
Cycle time at nominal load	L 507 L 509
Lifting	4.2 s 5.5 s
Dumping	1.5 s 1.9 s
Lowering (empty)	3.0 s 4.2 s



Operator's Cab

Design	The cab is resiliently mounted on the rear section, with built in ROPS/FOPS structure, tinted safety glass window, right-hand door with gap opener arrangement. Adjustable steering column available as optional extra. ROPS roll over protection per EN/ISO 3471/ EN 474-1 FOPS falling objects protection per EN/ISO 3449/ EN 474-1
Operator's seat	6 way adjustable seat with seat belt, adjustable for operator's weight (mechanically sprung)
Cab heating and ventilation	With defrosting, fresh-air filter, recirculation-air mode and hot-water heating



Noise Emission

ISO 6396	L _{PA} (inside cab)	= 70 dB(A)
2000/14/EG	L _{WA} (surround noise)	= 99 dB(A)



Capacities

	L 507	L 509
Fuel tank	l 80	80
Engine oil (including filter change)	l 10.2	10.2
Coolant	l 11	12
Front axle	l 6.1	9.2
Rear axle	l 5.5	8
Travel gear	l 0.6	0.8
Hydraulic tank	l 55	80
Hydraulic system total	l 90	100

Dimensions

L 507 - L 509

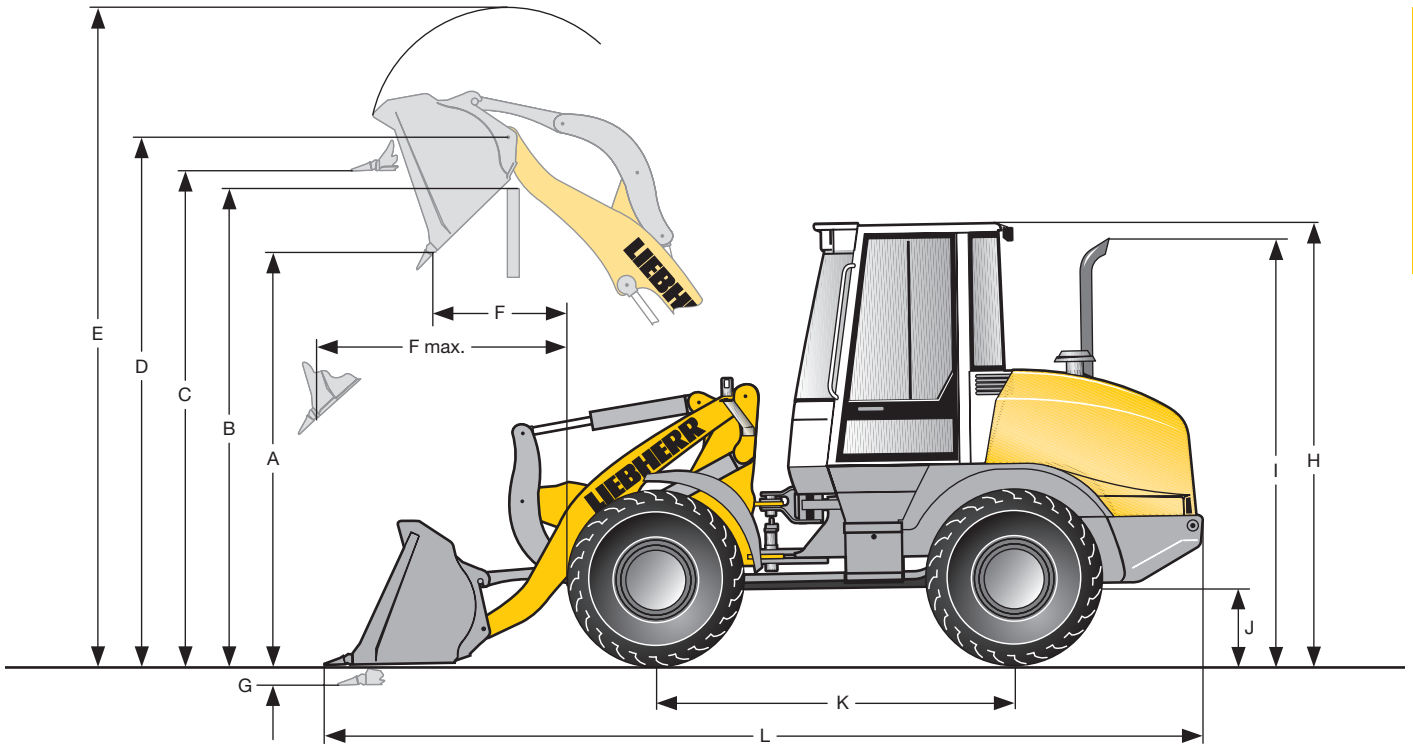

Loading Bucket

		L 507	L 509
	Cutting tools	T	T
	Lift arm length	mm	2,150
	Bucket capacity according to ISO 7546 **	m ³	0.9
	Bucket width	mm	2,050
A	Dumping height at max. lift height and 42° discharge	mm	2,550
B	Dump-over height	mm	2,872
C	Max. height of bucket bottom	mm	3,011
D	Max. height of bucket pivot point	mm	3,211
E	Max. operating height	mm	4,040
F	Reach at max. lift height and 42° discharge	mm	818
F max.	Max. outreach at 42° discharge	mm	1,517
G	Digging depth	mm	80
H	Height above cab	mm	2,748
I	Height above exhaust	mm	2,600
J	Ground clearance	mm	295
K	Wheelbase	mm	2,150
L	Overall length	mm	5,295
	Turning circle radius over outside bucket edge	mm	3,755
	Breakout force (SAE)	kN	48
	Tipping load, straight *	kg	4,065
	Tipping load, articulated 30° *	kg	3,712
	Operating weight *	kg	5,470
	Tyre sizes	365/70R18 L2	405/70R18 L2

* The figures shown here are valid with tyres above, includes all lubricants, a full fuel tank, the ROPS/FOPS cab and the operator. Different tyres and optional equipment will change the operating weight and tipping load. (Tipping load, articulated 30° according to ISO 14397-1).

** Actual bucket capacity may be approx. 10% larger than the calculation according to ISO 7546 standard. The degree to which the bucket can be filled depends on the material – see page 23.

T = Welded-on tooth holder with add-on teeth

Attachment

Light Material Bucket

L 507 - L 509

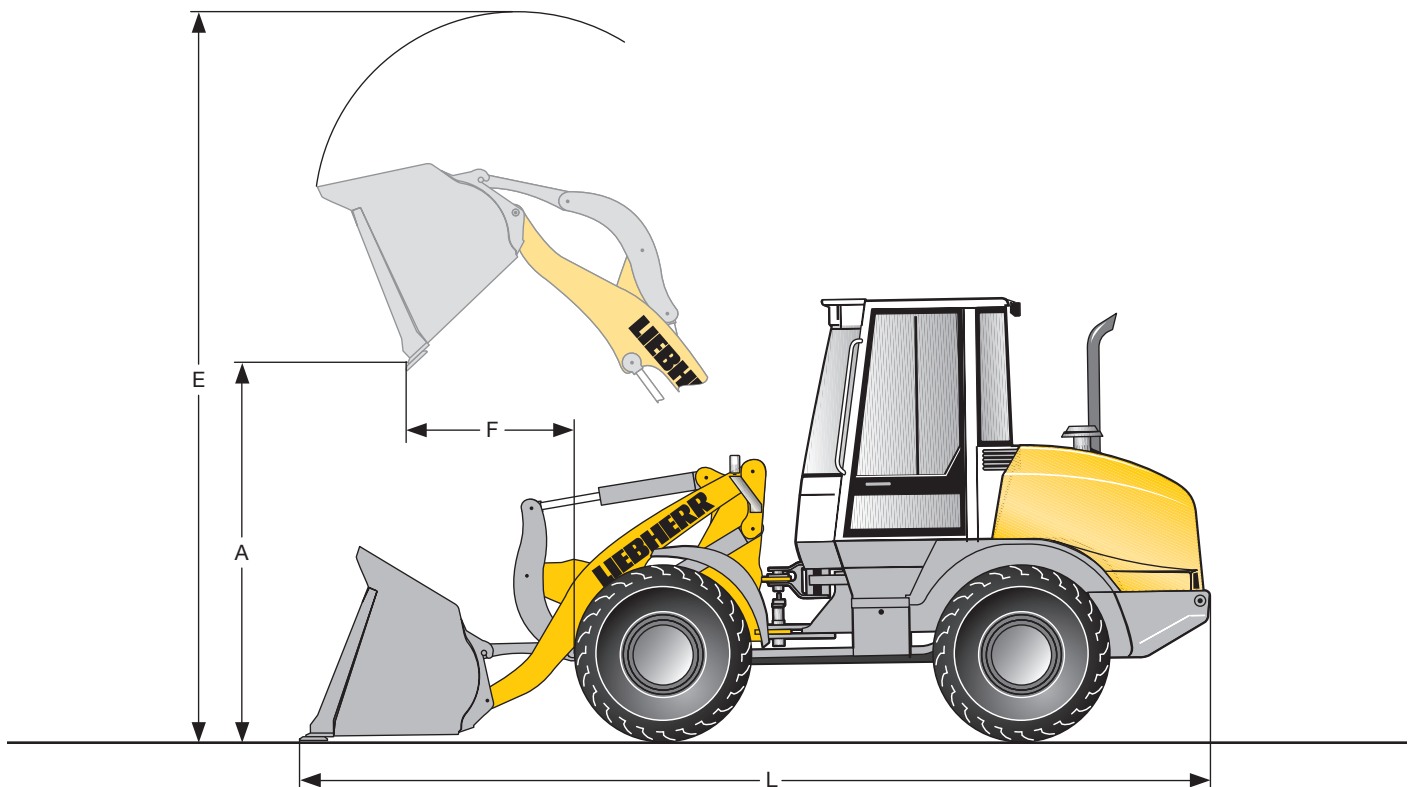

Light Material Bucket with Bolt-On Cutting Edge

		L 507		L 509		
	Bucket capacity	m ³	1.2	1.6	1.6	2.0
	Bucket width	mm	2,330	2,400	2,400	2,400
A	Dumping height at max. lift height and max. discharge	mm	2,511	2,420	2,551	2,460
E	Max. operating height	mm	4,123	4,196	4,325	4,474
F	Reach at maximum lift height and max. discharge	mm	866	890	937	1,048
L	Overall length	mm	5,355	5,410	5,742	5,882
	Tipping load, straight*	kg	3,919	3,824	4,746	4,692
	Tipping load, articulated 30°*	kg	3,575	3,491	4,317	4,268
	Operating weight*	kg	5,598	5,654	6,473	6,480
	Tyre sizes		365/70R18 L2		405/70R18 L2	

* The figures shown here are valid with tyres above, includes all lubricants, a full fuel tank, the ROPS/FOPS cab and the operator. Different tyres and optional equipment will change the operating weight and tipping load. (Tipping load, articulated 30° according to ISO 14397-1).

Attachment

4 in 1 Bucket

L 507 - L 509

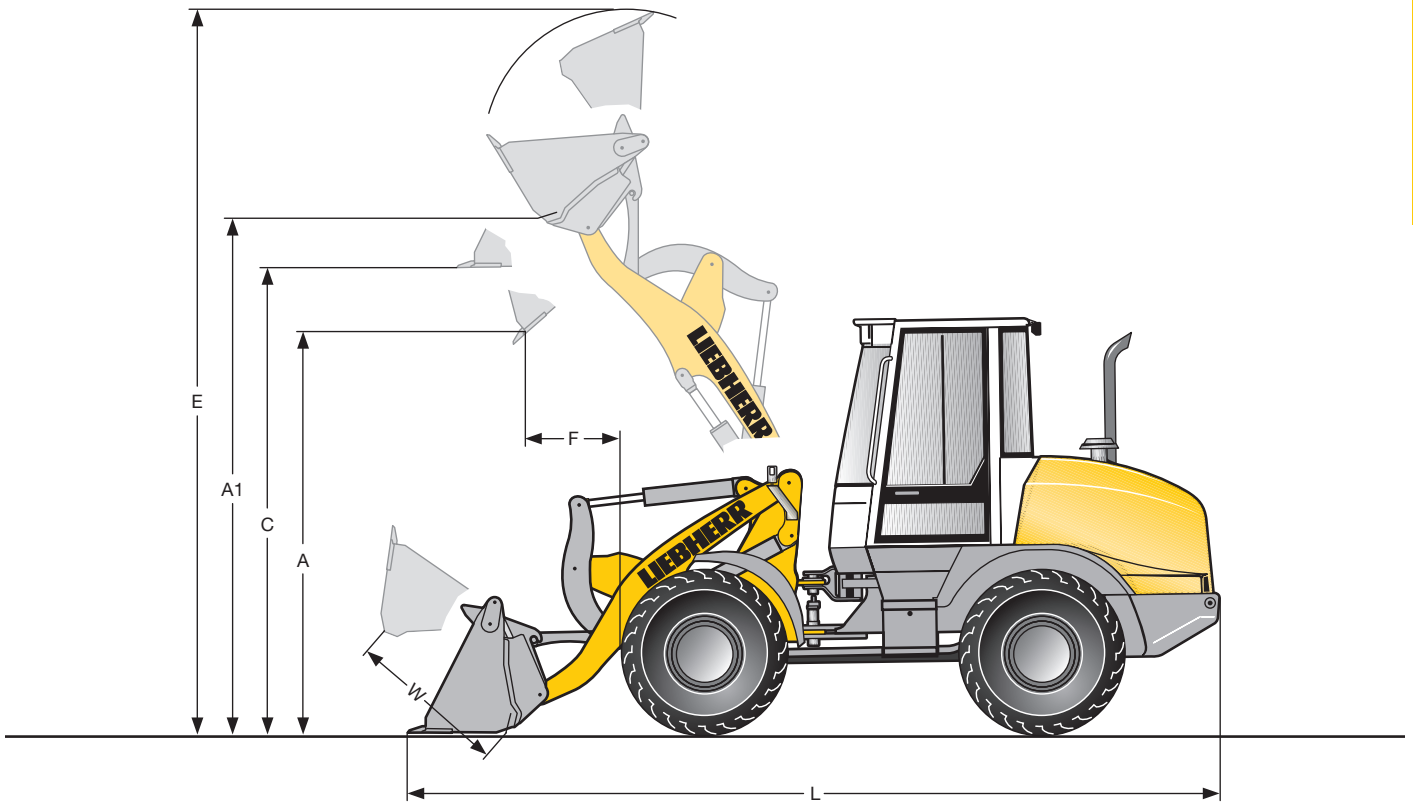

4 in 1 Bucket

		L 507	L 509
Cutting tools		T	T
Bucket capacity	m ³	0.8	1.0
Bucket width	mm	2,100	2,330
A	Dumping height at max. lift height and 42° discharge	2,532	2,634
A1	Max. dumping height with opened bucket	3,203	3,356
C	Max. height of bucket bottom	2,946	3,074
E	Max. operating height	4,714	4,895
F	Reach at max. lift height and 42° discharge	890	965
L	Overall length	5,390	5,835
W	Max. bucket opening	1,008	1,008
Turning circle radius over outside bucket edge		3,907	4,280
Tipping load, straight *		3,550	4,354
Tipping load, articulated 30° *		3,240	3,961
Operating weight *		5,757	6,681
Tyre sizes		365/70R18 L2	405/70R18 L2

* The figures shown here are valid with tyres above, includes all lubricants, a full fuel tank, the ROPS/FOPS cab and the operator. Different tyres and optional equipment will change the operating weight and tipping load. (Tipping load, articulated 30° according to ISO 14397-1).

T = Welded-on tooth holder with add-on teeth

Attachment

Fork Carrier and Fork

L 507 - L 509

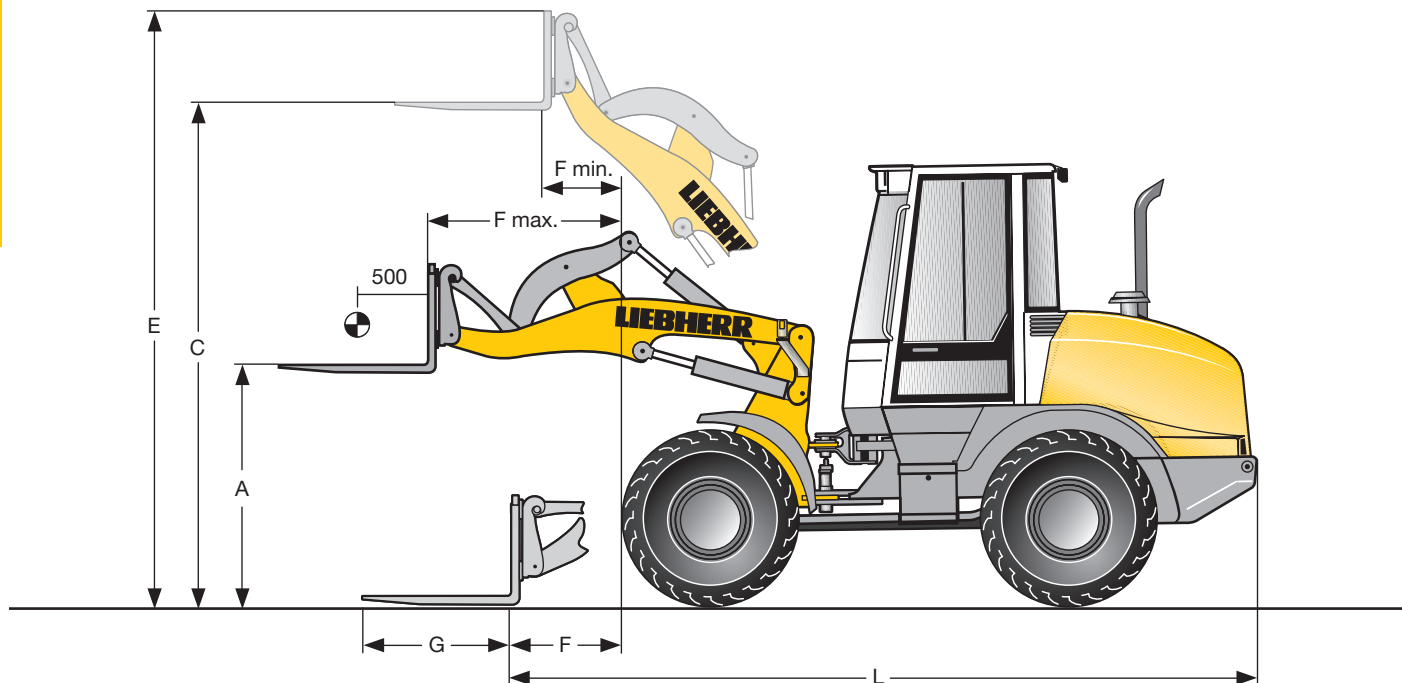

FEM II Fork Carrier and Fork for hydraulic quick-hitch

			L 507	L 509
A	Lifting height at max. reach	mm	1,452	1,515
C	Max. lifting height	mm	3,039	3,165
E	Max. operating height	mm	3,714	3,840
F	Reach at loading position	mm	741	775
F max.	Max. reach	mm	1,258	1,335
F min.	Reach at max. lifting height	mm	550	595
G	Fork length	mm	1,200	1,200
L	Length - basic machine	mm	4,605	4,940
	Tipping load, straight *	kg	3,145	3,858
	Tipping load, articulated 30° *	kg	2,652	3,250
	Recommended payload for uneven ground = 60% of tipping load (full articulated) ***	kg	1,660	2,040
	Recommended payload for smooth surfaces = 80% of tipping load (full articulated) ***	kg	2,212	2,500 **
	Operating weight *	kg	5,400	6,217
	Tyre sizes		365/70R18 L2	405/70R18 L2

* The figures shown here are valid with tyres above, includes all lubricants, a full fuel tank, the ROPS/FOPS cab and the operator. Different tyres and optional equipment will change the operating weight and tipping load. (Tipping load, articulated 30° according to ISO 14397-1).

** Payload on forks is limited by tilt cylinder - max. load capacity for the fork carrier FEM II 2,500 kg

*** According to EN 474-3

Technical Data



Engine

Diesel engine	4045 HFL 92C	
Design	4-cylinder inline engine, water-cooled with exhaust turbocharger, intercooler and diesel particle filter	
Fuel injection process	electronic Common Rail high-pressure injection	
Max. output according to DIN/ISO 3046	77 kW	at 2,000 RPM
Max. torque	413 Nm	at 1,400 RPM
Displacement	4.5 litres	
Bore/Stroke	106/127 mm	
Air cleaner	Dry air filter with main and safety element	
Electrical system		
Operating voltage	12 V	
Battery	2 x 100 Ah/12 V	
Alternator	12 V/90 A	
Starter motor	4.8 kW	

The exhaust emissions are below the limits in stage IIIB / Tier 4i.

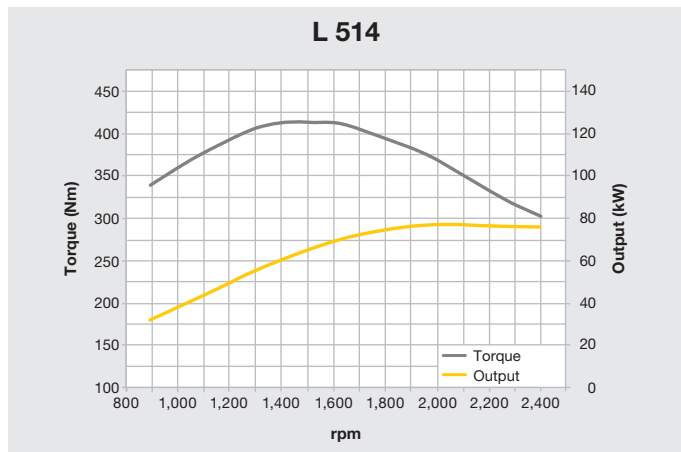

Travel Gear

Stepless hydrostatic travel drive		
Design	Swash plate type variable flow pump and a variable axial piston motor in a closed loop circuit	
Filtering system	Suction return line filter for closed circuit	
Control	Control of travel drive with travel and combined inching pedal. The inching pedal permits continuously variable adjustment of crowding and tractive force to match ground and operating conditions. The Liebherr joystick is used to control forward and reverse travel	
Travel speeds	Speed range 1	0 – 8.0 km/h
	Speed range 2	0 – 30.0 km/h
	Forward and reverse with tyre size 17.5R25	



Axles

Four-wheel drive		
Front axle	Fixed	
Steered rear axle	Centre pivot, with 5° oscillating angle to each side	
Differentials	Automatic limited-slip differentials with 45% locking action in both axles	
Final drive	Planetary final drive in the wheel hubs	
Track width	1,920 mm	



Brakes

Service brake	Dual-circuit brake system, drum brake and wet multi-disc brake on front axle	
Parking brake	"Negative brake system" on front axle acting on the wet multi-disc brakes	

The braking system meets the requirements of the EC guidelines 71/320.



Steering

Design	"Stereo" steering system, hydraulic servo power steering. Central oscillating frame articulation in combination with rear-axle pivot steering, and damper element	
Angle of articulation	30° to each side	
Angle of oscillation – Centre-pivot steering	5° to each side	
Max. pressure	180 bar	



Attachment Hydraulics

Design	Gear pump to supply the hydraulic and steering systems (via priority valve)	
Max. flow	115 l/min.	
Max. pressure	230 bar	
Cooling	Hydraulic oil cooling by thermostatically controlled fan and oil cooler	
Filtering	Return-line filter in the hydraulic reservoir	
Control	Single-lever control with Liebherr Joystick, hydraulically actuated, with load-dependent delivery rate distribution	
Lift circuit	Lifting, neutral, lowering and float positions controlled by Liebherr joystick with detent; automatic lifting-limit circuit	
Tilt circuit	Tilt back, neutral, dump automatic bucket positioning	



Attachment

Geometry can be chosen	Powerful Z-pattern linkage with one tilt cylinder, hydr. quick change coupler – optional equipment Parallel linkage with two tilt cylinders, hydr. quick change coupler – standard equipment	
Bearings	Sealed	
Cycle time at nominal load	ZK	PK
Lifting	5.5 s	7.3 s
Dumping	1.6 s	4.2 s
Lowering (empty)	3.5 s	2.7 s



Operator's Cab

Design	The cab is resiliently mounted on the rear section, with built in ROPS/FOPS structure, tinted safety glass window, right-hand door with gap opener arrangement. Adjustable steering column available as optional extra ROPS roll over protection per EN/ISO 3471/ EN 474-1 FOPS falling objects protection per EN/ISO 3449/ EN 474-1	
Operator's seat	6 way adjustable seat with seat belt, adjustable for operator's weight (mechanically sprung)	
Cab heating and ventilation	With defrosting, fresh-air filter, airrecirculated-air mode and heater supplied from engine's cooling system. Air conditioning is optional equipment	



Noise Emission

ISO 6396	L_{pA} (inside cab)	= 70 dB(A)
2000/14/EC	L_{WA} (surround noise)	= 100 dB(A)



Capacities

Fuel tank	160 l
Engine oil (including filter change)	13 l
Travel gear and rear axle differential	2 l
Front axle/differential	8.9 l
Rear axle/differential	8.7 l
Hydraulic tank	95 l
Hydraulic system total	125 l

L 514

Dimensions

L 514

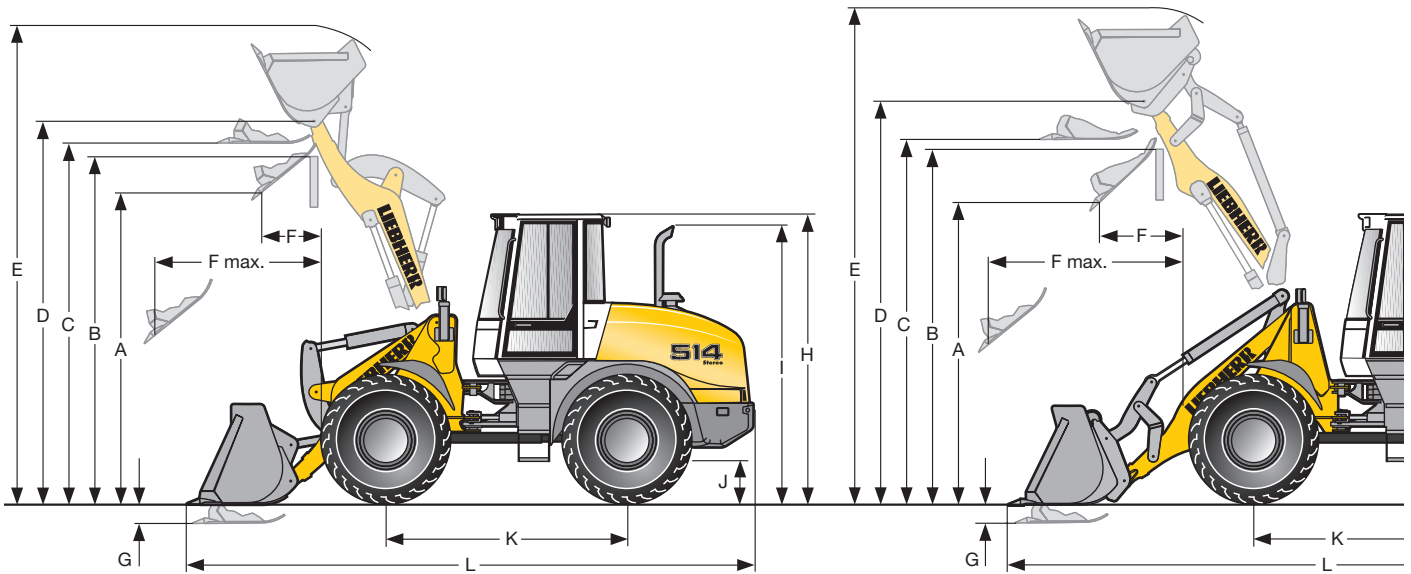

Loading Bucket



		ZK	ZK	ZK	PK	
	Geometry					
	Cutting tools	T	T	T	T	
	Lift arm length	mm	2,350	2,350	2,400	
	Bucket capacity according to ISO 7546 **	m ³	1.5	1.7	1.4	
	Bucket width	mm/kg	2,400/620	2,400/655	2,400/590	
A	Dumping height at max. lift height and 44° discharge	mm	2,855	2,710	2,775	2,985
B	Dump-over height	mm	3,260	3,260	3,260	3,430
C	Max. height of bucket bottom	mm	3,440	3,440	3,440	3,610
D	Max. height of bucket pivot point	mm	3,675	3,675	3,675	3,860
E	Max. operating height	mm	4,550	4,725	4,680	4,840
F	Reach at max. lift height and 44° max. discharge	mm	830	955	915	785
F max.	Max. outreach at 44° discharge	mm	1,500	1,560	1,608	1,703
G	Digging depth	mm	53	53	53	35
H	Height above cab	mm	3,070	3,070	3,070	3,070
I	Height above exhaust	mm	2,890	2,890	2,890	2,890
J	Ground clearance	mm	385	385	385	385
K	Wheelbase	mm	2,600	2,600	2,600	2,600
L	Overall length	mm	6,135	6,340	6,395	6,330
	Turning circle radius over outside bucket edge (carry position)	mm	4,510	4,610	4,565	4,610
	Breakout force (SAE)	kN	77	72	72	77
	Tipping load, straight*	kg	6,200	6,100	5,745	5,385
	Tipping load, articulated at 30°*	kg	5,680	5,590	5,260	4,920
	Operating weight*	kg	8,350	8,390	8,510	8,520
	Tyre sizes		17.5R25 L3	17.5R25 L3	17.5R25 L3	17.5R25 L3

* The figures shown here are valid with tyres above, includes all lubricants, a full fuel tank, the ROPS/FOPS cab and the operator. Different tyres and optional equipment will change the operating weight and tipping load. (Tipping load, articulated 30° according to ISO 14397-1).

** Actual bucket capacity may be approx. 10% larger than the calculation according to ISO 7546 standard. The degree to which the bucket can be filled depends on the material – see page 23.

ZK = Z-bar linkage

PK = Parallel linkage with quick coupler

T = Welded-on tooth holder with add-on teeth

Notice: Quick hitch compatibility between L 514Stereo up to L 524 – L 538.

Attachment

Light Material Bucket

High-Dump Bucket

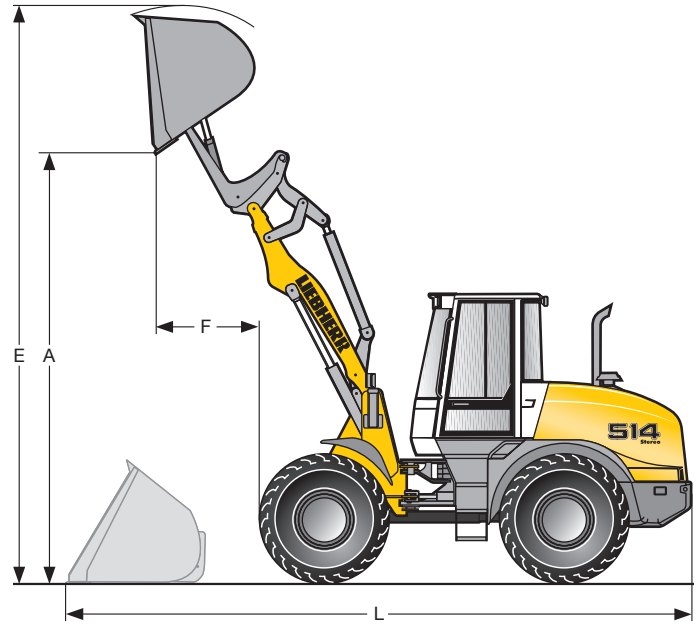
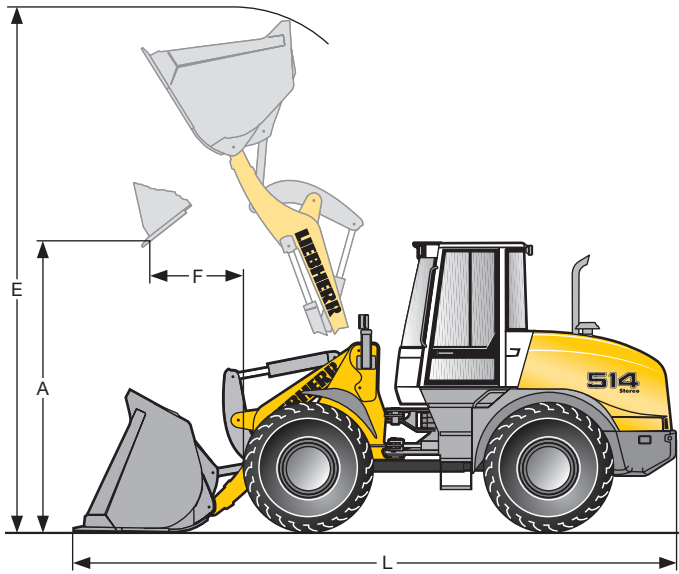

L 514

Light Material Bucket with Bolt-On Cutting Edge



Geometry		ZK	PK
Bucket capacity	m ³	2.0	2.0
Bucket width	mm	2,500	2,500
A Dumping height at max. lift height	mm	2,757	2,870
E Max. operating height	mm	4,845	5,075
F Reach at maximum lift height	mm	930	940
L Overall length	mm	6,290	6,535
Tipping load, straight *	kg	5,600	5,155
Tipping load, articulated 30° *	kg	5,450	4,720
Operating weight *	kg	8,500	8,683
Tyre sizes		17.5R25 L3	17.5R25 L3

High-Dump Bucket with Bolt-On Cutting Edge



Geometry		ZK	ZK	PK	PK
Discharge angle		26° ¹⁾	40° ²⁾	26° ¹⁾	40° ²⁾
Bucket capacity	m ³	2.5	2.5	2.5	2.5
Bucket width	mm	2,490	2,490	2,490	2,490
A Dumping height at max. lift height	mm	4,470	4,140	4,575	4,285
E Max. operating height	mm	6,035	5,850	6,160	5,945
F Reach at maximum lift height	mm	1,230	1,400	1,235	1,385
L Overall length	mm	6,685	6,685	6,840	6,840
Tipping load, straight *	kg	4,790	4,790	4,250	4,250
Tipping load, articulated 30° *	kg	4,380	4,380	3,890	3,890
Operating weight *	kg	9,490	9,490	9,490	9,490
Tyre sizes		17.5R25 L3	17.5R25 L3	17.5R25 L3	17.5R25 L3

* The figures shown here are valid with tyres above, includes all lubricants, a full fuel tank, the ROPS/FOPS cab and the operator. Different tyres and optional equipment will change the operating weight and tipping load. (Tipping load, articulated 30° according to ISO 14397-1).

ZK = Z-bar linkage

PK = Parallel linkage with quick coupler

¹⁾ Actuation of the function: "Discharge high-dump bucket"

²⁾ Discharge by way of the function "High-dump bucket" and standard tipping function

Notice: Quick hitch compatibility between L 514Stereo up to L 524 – L 538.

Attachment

Fork Carrier and Fork

L 514

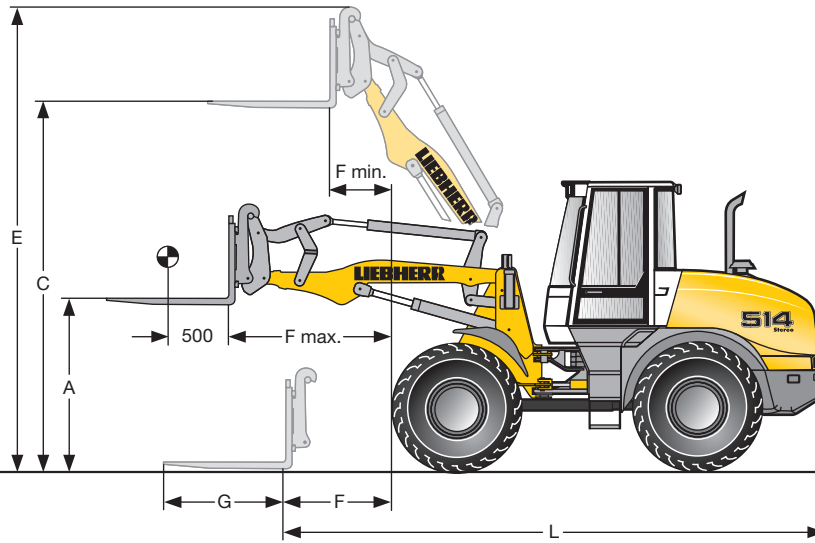

FEM III Fork Carrier and Fork for hydraulic quick-hitch



Geometry			ZK	PK
A	Lifting height at max. reach	mm	1,715	1,700
C	Max. lifting height	mm	3,497	3,655
E	Max. operating height	mm	4,420	4,580
F	Reach at loading position	mm	815	965
F max.	Max. reach	mm	1,500	1,615
F min.	Reach at max. lifting height	mm	678	605
G	Fork length	mm	1,200	1,200
L	Length – basic machine	mm	5,610	5,640
	Tipping load, straight *	kg	4,400	4,230
	Tipping load, articulated 30° *	kg	4,030	3,870
	Recommended payload for uneven ground = 60% of tipping load (full articulated) ***	kg	2,410	2,320
	Recommended payload for smooth surfaces = 80% of tipping load (full articulated) ***	kg	2,840	3,095
	Operating weight *	kg	8,370	8,365
	Tyre sizes		17.5R25 L3	17.5R25 L3

* The figures shown here are valid with tyres above, includes all lubricants, a full fuel tank, the ROPS/FOPS cab and the operator. Different tyres and optional equipment will change the operating weight and tipping load. (Tipping load, articulated 30° according to ISO 14397-1).

*** According to EN 474-3

ZK = Z-bar linkage with quick coupler

PK = Parallel linkage with quick coupler

Notice: Quick hitch compatibility between L 514Stereo up to L 524 – L 538.

Tipping Load

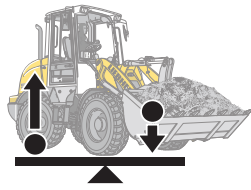

ISO 14397-1

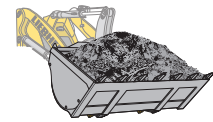

What is tipping load?

Load at centre of gravity of working equipment, so that the wheel loader just begins to tip over the front axle. This is the most unfavourable static-load position for the wheel loader. Lifting arms horizontal, wheel loader fully articulated at centre pivot.

Pay load.

The pay load must not exceed 50% of the tipping load when articulated. This is equivalent to a static stability-margin factor of 2.0.

Bucket capacity.

The bucket volume is determined from the pay load.

$$\text{Pay load} = \frac{\text{Tipping load, articulated}}{2}$$

$$\text{Bucket capacity} = \frac{\text{Pay load (t)}}{\text{Specific bulk weight of material (t/m}^3\text{)}}$$

Bucket selection

L 507

Lift arm	Bucket	Material density (t/m ³)								
		0.4	0.6	0.8	1.0	1.2	1.4	1.6	1.8	2.0
ZK	GPB 0.9 m ³							1.0		0.9
	LMB 1.2 m ³					1.3		1.2		
	LMB 1.6 m ³				1.8		1.6			
	4in1 0.8 m ³							0.9		0.8

L 509

Lift arm	Bucket	Material density (t/m ³)								
		0.4	0.6	0.8	1.0	1.2	1.4	1.6	1.8	2.0
ZK	GPB 1.2 m ³								1.3	1.2
	LMB 1.6 m ³						1.8		1.6	
	LMB 2.0 m ³					2.2		2.0		
	4in1 1.0 m ³								1.1	1.0

L 514

Lift arm	Bucket	Material density (t/m ³)								
		0.4	0.6	0.8	1.0	1.2	1.4	1.6	1.8	2.0
ZK	GPB 1.5 m ³							1.7		1.5
	LMB 1.7 m ³						1.9		1.7	
	LMB 2.0 m ³					2.2		2.0		
HDB	2.5 m ³			2.8		2.5				
	ZK-QH GPB 1.5 m ³							1.7		1.5
PK	GPB 1.4 m ³							1.5		1.4
	LMB 2.0 m ³					2.2		2.0		
	HDB 2.5 m ³			2.8		2.5				

Bucket Filling Factor

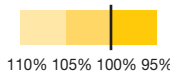

Lift arm

ZK	Z-bar linkage, standard lift arm length
ZK-QH	Z-bar linkage including quick-hitch, standard lift arm length
PK	Parallel linkage including quick-hitch, standard lift arm length





Bucket





GPB	General purpose bucket (Excavation)
LMB	Light material bucket
HDB	High-dump bucket
4in1	4 in 1 Bucket





Bulk Material Densities and Bucket Filling Factors

		t/m ³	%			t/m ³	%		t/m ³	%	
Gravel,	moist	1.9	105	Earth,	dry	1.3	115	Glass waste,	broken	1.4	100
	dry	1.6	105		wet excavated	1.6	110		solid	1.0	100
	crushed stone	1.5	100	Topsoil		1.1	110	Compost,	dry	0.8	105
Sand,	dry	1.5	105	Basalt		1.95	100		wet	1.0	110
	wet	1.9	110	Granite		1.8	95	Wood chips / saw dust		0.5	110
Gravel and sand,	dry	1.7	105	Sandstone		1.6	100	Paper,	shredded / loose	0.6	110
	wet	2.0	100	Slate		1.75	100		recovered paper / cardboard	1.0	110
Sand / clay		1.6	110	Bauxite		1.4	100	Coal,	heavy material density	1.2	110
Clay,	natural	1.6	110	Limestone		1.6	100		light material density	0.9	110
	dry	1.4	110	Gypsum, broken		1.8	100	Waste,	domestic waste	0.5	100
Clay / gravel,	dry	1.4	110	Coke		0.5	110		bulky waste	1.0	100
	wet	1.6	100	Slag, broken		1.8	100				

The Liebherr Wheel Loaders

Wheel Loader						
		L 506^{Compact}	L 507^{Stereo}	L 508^{Compact}	L 509^{Stereo}	L 514^{Stereo}
Tipping load	kg	3,450	3,712	3,850	4,430	5,680
Bucket capacity	m ³	0.8	0.9	1.0	1.2	1.5
Operating weight	kg	5,180	5,470	5,600	6,390	8,350
Engine output	kW/HP	46/63	50/68	50/68	54/73	77/105

Wheel Loader						
		L 524	L 528	L 538	L 542	L 550
Tipping load	kg	7,500	8,500	9,500	10,200	12,150
Bucket capacity	m ³	2.1	2.3	2.6	2.8	3.2
Operating weight	kg	10,400	10,900	12,800	13,400	17,300
Engine output	kW/HP	90/122	100/136	115/156	120/163	129/175

Wheel Loader						
		L 556	L 566	L 576	L 580	L 586
Tipping load	kg	13,550	15,750	17,500	18,500	20,430
Bucket capacity	m ³	3.6	4.0	4.5	5.0	5.5
Operating weight	kg	17,900	23,150	24,450	25,180	31,380
Engine output	kW/HP	140/191	190/259	205/279	215/292	250/340

07.13

Tyres

		Size and tread code	Change of operating weight kg	Width over tyres mm	Change in vertical dimensions mm	Use
L 507^{Stereo}						
Bridgestone	405/70R20 VUT	L2	+ 120	1,930	+ 47	Gravel, Asphalt (all ground conditions)
Dunlop	365/70R18 SP T9	L2	0	1,890	0	Sand, Gravel, Asphalt (all ground conditions)
Dunlop	405/70R18 SP T9	L2	+ 56	1,920	+ 23	Sand, Gravel, Asphalt (all ground conditions)
Dunlop	365/80R20 SP T9	L2	+ 76	1,890	+ 55	Sand, Gravel, Asphalt (all ground conditions)
Dunlop	405/70R20 SP T9	L2	+ 112	1,920	+ 49	Sand, Gravel, Asphalt (all ground conditions)
Dunlop	15.5/55R18 SP PG7	L2	- 16	1,900	- 29	Sand, Gravel, Asphalt (all ground conditions)
Dunlop	405/70R20 PG 75 RCL	L5	+ 248	1,920	+ 57	Stone, Scrap, Recycling (firm ground conditions)
Firestone	340/80R18 Duraforce UT	L3	+ 37	1,880	+ 14	Gravel, Asphalt, Industry (all ground conditions)
Firestone	405/70R18 Duraforce UT	L3	+ 108	1,930	+ 22	Gravel, Asphalt, Industry (all ground conditions)
Firestone	365/80R20 Duraforce UT	L3	+ 96	1,900	+ 52	Gravel, Asphalt, Industry (all ground conditions)
Firestone	400/70R20 Duraforce UT	L3	+ 138	1,920	+ 42	Gravel, Asphalt, Industry (all ground conditions)
Michelin	9.00R20 X MINE D2	L5	+ 340	1,900	+ 46	Stone, Scrap, Recycling (firm ground conditions)
Michelin	375/75R20 XZSL	L3	+ 122	1,920	+ 51	Gravel, Asphalt, Industry (firm ground conditions)
Michelin	405/70R20 XZSL	L3	+ 145	1,930	+ 65	Gravel, Asphalt, Industry (firm ground conditions)
Michelin	400/70R20 XMCL	L2	+ 128	1,930	+ 43	Earthworks, Green area (all ground conditions)
Mitas	365/70R18 EM-01	L2	+ 16	1,900	- 1	Gravel, Asphalt (all ground conditions)
Mitas	365/80R20 EM-01	L2	+ 88	1,900	+ 51	Gravel, Asphalt (all ground conditions)
Mitas	405/70R18 EM-01	L2	+ 72	1,930	+ 24	Gravel, Asphalt (all ground conditions)
Mitas	405/70R20 EM-01	L2	+ 108	1,930	+ 49	Gravel, Asphalt (all ground conditions)
L 509^{Stereo}						
Dunlop	405/70R18 SP T9	L2	0	2,050	0	Sand, Gravel, Asphalt (all ground conditions)
Dunlop	405/70R20 SP T9	L2	+ 56	2,050	+ 26	Sand, Gravel, Asphalt (all ground conditions)
Dunlop	405/70R20 PG 75 RCL	L5	+ 192	2,050	+ 34	Stone, Scrap, Recycling (firm ground conditions)
Dunlop	455/70R20 SP T9	L2	+ 126	2,160	+ 55	Sand, Gravel, Asphalt (all ground conditions)
Firestone	365/80R20 Duraforce UT	L3	+ 40	2,030	+ 29	Gravel, Asphalt, Industry (all ground conditions)
Firestone	400/70R20 Duraforce UT	L3	+ 82	2,050	+ 19	Gravel, Asphalt, Industry (all ground conditions)
Firestone	405/70R18 Duraforce UT	L3	+ 52	2,060	- 1	Gravel, Asphalt, Industry (all ground conditions)
Michelin	9.00R20 X MINE D2	L5	+ 284	2,030	+ 23	Stone, Scrap, Recycling (firm ground conditions)
Michelin	405/70R20 XZSL	L3	+ 89	2,060	+ 42	Gravel, Asphalt, Industry (firm ground conditions)
Michelin	400/70R20 XMCL	L2	+ 72	2,060	+ 20	Earthworks, Green area (all ground conditions)
Michelin	425/70R20 XZSL	L3	+ 100	2,140	+ 49	Gravel, Asphalt, Industry (firm ground conditions)
Mitas	405/70R18 EM-01	L2	+ 16	2,060	+ 1	Gravel, Asphalt (all ground conditions)
Mitas	405/70R20 EM-01	L2	+ 52	2,060	+ 26	Gravel, Asphalt (all ground conditions)
L 514^{Stereo}						
Bridgestone	17.5R25 VUT	L2	- 47	2,360	+ 4	Gravel, Earthworks, Clay (all ground conditions)
Bridgestone	17.5R25 VJT	L3	+ 91	2,360	+ 18	Bulk material (firm ground conditions)
Bridgestone	15.5R25 VSDL	L5	+ 374	2,340	+ 24	Gravel, Earthworks, Clay (all ground conditions)
Bridgestone	17.5R25 VSDL	L5	+ 628	2,360	+ 57	Stone, Scrap, Recycling (firm ground conditions)
Bridgestone	550/65R25 VTS	L3	+ 377	2,470	+ 12	Gravel (all ground conditions)
Goodyear	17.5R25 RT-3B	L3	+ 165	2,380	+ 21	Gravel (all ground conditions)
Goodyear	17.5R25 TL-3A+	L3	+ 233	2,380	+ 23	Sand, Gravel, Earthworks, Clay (all ground conditions)
Goodyear	17.5R25 RL-4K	L4	+ 545	2,370	+ 42	Gravel, Industry, Stone (firm ground conditions)
Goodyear	17.5R25 RL-5K	L5	+ 669	2,370	+ 42	Stone, Scrap, Recycling (firm ground conditions)
Michelin	17.5R25 XHA	L3	0	2,370	0	Sand, Gravel (all ground conditions)
Michelin	17.5R25 XLDD2A	L5	+ 354	2,370	+ 37	Stone, Mining spoil (firm ground conditions)
Michelin	550/65R25 XLD65	L3	+ 427	2,470	+ 18	Gravel (all ground conditions)
Michelin	15.5R25 X MINE D2	L5	+ 461	2,370	+ 27	Stone, Scrap, Recycling (firm ground conditions)
Michelin	17.5R25 X MINE D2	L5	+ 538	2,400	+ 59	Stone, Scrap, Recycling (firm ground conditions)

Before operating the vehicle with tyre foam filling or tyre protection chains, please discuss this with the Liebherr-Werk Bischofshofen GmbH.

Equipment



Basic Machine

	507	509	514
Automatic central lubrication system	+	+	+
Battery master switch	•	•	•
Tool kit	•	•	•
Diesel particle filter	•	•	•
Electronical theft protection	+	+	+
Automatic travel mode	•	•	•
Ride control	+	+	+
Particle protection for radiator	+	+	+
Pre-heat system for cold starting	•	•	•
Combined inching-braking system	•	•	•
Multi-disc limited slip differentials in both axles	•	•	•
LiDAT (Liebherr Data Transfer System)	+	+	+
Liebherr shock absorbing element	•	•	•
Air cleaner system with pre-filter	•	•	•
Emergency steering system	•	•	•
Warning device for travel in reverse	+	+	+
Tail lights, single version	•	•	•
Amber beacon	+	+	+
Headlights front, single version (on front chassis) – halogen	•	•	•
Protective ventilation system	+	+	+
30 km/h Maximum speed – Speeder -version only	+	+	•
Dust filter system	+	+	+
Lockable doors, service flap and engine hood	•	•	•
Load lashing lugs	•	•	•
Air pre-cleaner	+	+	+
Towing hitch	•	•	•
Additional toolbox in access step area	+	+	+
20 km/h speed limiting – Speeder -version only	+	+	+



Operator's Cab

	507	509	514
Storage compartment	•	•	•
Storage box	•	•	•
Ashtray	•	•	•
Folding outside mirrors	•	•	•
Tool kit	•	•	•
Operator's package	•	•	•
Operator's seat – mechanically adjustable in 6 ways	•	•	•
Operator's seat – air sprung	+	+	+
Operator's seat – air sprung with seat heating	+	+	+
Fire extinguisher 2 kg	•	•	•
Cup holder	•	•	•
Horn	•	•	•
Floor mat	•	•	•
Clothes hook	•	•	•
Air conditioning system	+	+	+
Steering column, adjustable	+	+	+
Emergency exit	•	•	•
Radio set	+	+	+
Provision for radio including loudspeaker	+	+	+
Interior rear-view mirror	•	•	•
Soundproof ROPS/FOPS cab	•	•	•
Wash/wipe system for windscreen and rear window	•	•	•
Headlights rear, single or in double cluster – halogen	+	+	+
Headlights front, in double cluster – halogen	+	+	+
Headlights front, single version – halogen	•	•	•
Sliding window	+	+	+
Sun visor	•	•	•
Plug 12 V	•	•	•
First aid kit	+	+	+
Hot-water heater with defroster and recirculated-air system	•	•	•



Instruments for

	507	509	514
Timer for hours of operation	•	•	•
Flashing turn indicators	•	•	•
Diagnosis system – Speeder -version only	•	•	•
Rev. counter – Speeder -version only	•	•	•
Travel speed ranges and gear selected	•	•	•
High-beam headlights	•	•	•
Fuel reserve	•	•	•
Engine oil temperature	-	-	•
Engine oil temperature – Speeder -version only	•	•	•
Reverse travel	•	•	•
Speedometer – Speeder -version only	•	•	•
Clock – Speeder -version only	-	-	•
Diesel engine pre-heat	•	•	•
Forward travel	•	•	•



Warning Lights for

	507	509	514
Emissions temperature high	•	•	•
Battery charge	•	•	•
Diesel particle filter	•	•	•
Parking brake	•	•	•
Hydraulic oil temperature	•	•	•
Air cleaner blockage	•	•	•
Engine oil pressure	•	•	•
Engine stop	•	•	•
Engine overheat	•	•	•
Engine error	•	•	•



Audible Warnings for

	507	509	514
Overheat of hydraulic fluid	•	•	•
Engine oil pressure	•	•	•
Engine stop	•	•	•
Engine overheat	•	•	•
Engine error	•	•	•
Emergency steering system	•	•	•



Function Keys for

	507	509	514
Working lights rear	+	+	+
Working lights front	•	•	•
Diesel particulate filter operation	•	•	•
Speed range selection	•	•	•
Ride control	+	+	+
Parking brake – Speeder -version only	•	•	•
Hoist kick out	+	+	+
Air conditioning	•	•	•
Creep speed	•	•	•
Mode switch for speed, operating hour, engine speed – Speeder -version only	•	•	•
Mode switch for speed, operating hour, clock – Speeder -version only	-	-	-
Amber beacon	+	+	+
Automatic bucket positioner	•	•	•
Wash/wipe system for rear window	•	•	•
Headlights	•	•	•
Float position	•	•	•
Road travel	•	•	•
Hazard warning flashers	•	•	•
Locking of additional function	+	+	+



Rotary Switches for

	507	509	514
Fresh-air or recirculated-air system	•	•	•
Blower	•	•	•
Heater	•	•	•



Equipment

	507	509	514
Automatic hoist kick out – adjustable	+	+	+
Automatic bucket positioner – adjustable	•	•	•
Fork carrier and lift forks	+	+	+
High-dump bucket	+	+	+
Hydraulic quick-change device – Parallel linkage	-	-	•
Hydraulic quick-change device – Z-bar linkage	•	•	•
Hydraulic servo control of working hydraulics	•	•	•
Loading buckets with and without teeth, or bolt-on cutting edge	+	+	+
Country-specific versions	+	+	+
Light material bucket	+	+	+
Parallel linkage	-	-	+
Load holding valves	+	+	+
Float position	•	•	•
Z-bar linkage	•	•	•
3rd hydraulic control circuit	+	+	+
3rd and 4th hydraulic control circuits	+	+	+

• = Standard, + = Option, - = not available

507-514 01.14

The Liebherr Group of Companies



Wide Product Range

The Liebherr Group is one of the largest construction equipment manufacturers in the world. Liebherr's high-value products and services enjoy a high reputation in many other fields. The wide range includes domestic appliances, aerospace and transportation systems, machine tools and maritime cranes.

Exceptional Customer Benefit

Every product line provides a complete range of models in many different versions. With both their technical excellence and acknowledged quality, Liebherr products offer a maximum of customer benefits in practical application.

State-of-the-art Technology

To provide consistent, top quality products, Liebherr attaches great importance to each product area, its components and core technologies. Important modules and components are developed and manufactured in-house, for instance the entire drive and control technology for construction equipment.

Worldwide and Independent

Hans Liebherr founded the Liebherr family company in 1949. Since that time, the enterprise has steadily grown to a group of more than 130 companies with over 39,000 employees located on all continents. The corporate headquarters of the Group is Liebherr-International AG in Bulle, Switzerland. The Liebherr family is the sole owner of the company.

www.liebherr.com

Liebherr-Werk Bischofshofen GmbH

Postfach 49, A-5500 Bischofshofen

☎ +43 50809 1-0, Fax +43 50809 11385

www.liebherr.com, E-Mail: info.lbh@liebherr.com

www.facebook.com/LiebherrConstruction