

# TRACK LOADER T985



TRACK LOADERS



# SKID LOADER T985

## WEIGHT/OPERATING WEIGHT

T985.32 Kg. 4.550/Kg. 1.470

T985.45 Kg. 4.700/Kg. 1.592

## ENGINE POWER

Kw 72,8

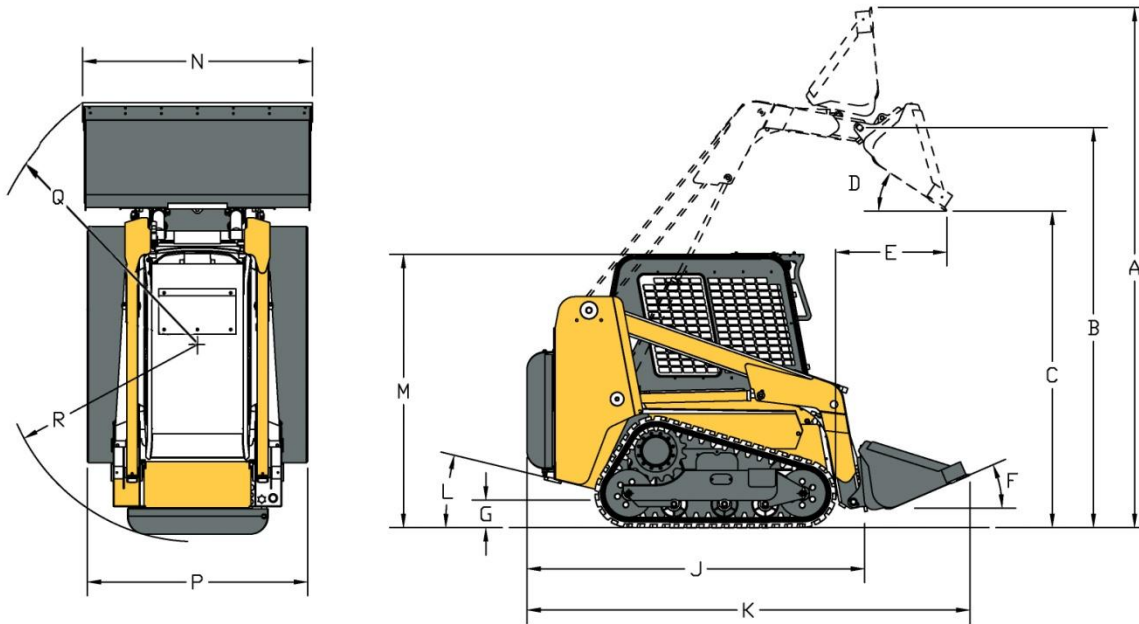

DIMENSIONI		T985.32	T985.45
A – Maximum operating height	mm	4.075	
B – Bucket pin height	mm	3.098	
C – Dump height	mm	2.281	
D – Dump angle	°	40	
E – Dump clearance at max height	mm	810	
F – Bucket closure angle	°	31	
G – Altezza minima da suolo	mm	205	
J – Total length without bucket	mm	2.769	
K – Total length with standard bucket	mm	3.482	
L – Rear starting angle	°	29	
M – Maximum machine height	mm	2.079	
N – Max. width with standard bucket	mm	1.980	2.170
P – Max width without standard bucket	mm	1.930	2.155

CARATTERISTICHE TECNICHE		T985.32	T985.45
Operating weight	Kg	4550	4600
Operating capacity 50%	Kg	1470	1592
Operating capacity 35%	Kg	1030	1114
Tipping load	Kg	2942	3183
Speed	Km/h	0-8,5/13,5	
Fuel tank capacity oil/diesel	l	38/66	
Engine		KUBOTA	
Displacement	cc	3.800 turbo	
Net power / rpm	Kw	72,8 / 2600	
Hydrostatic drive pumps	bar l/min	350 2x125	
Gear pump	bar l/min	180 77,5	
High flow	bar l/min	180 180	
Cooling system		Heat exchanger	
Tracks		320x86x52	450x86x52

CAMS MACCHINE S.P.A.

Strada S. Michele, 37 Cailungo B5 BORGO MAGGIORE R.S.M.

Tel. +378.0549.988111 Fax +378.0549.903793

[www.camsgroup.com](http://www.camsgroup.com) info@camsgroup.com

