



**DIECI**

**AGRI MAX**

50.8 | 65.8 | 60.9



## ***ABSOLUTE QUALITY*** *EXCELLENCE ON A HUMAN SCALE*

The characteristics of Dieci products can be summarized in three concepts that have always been the hallmark of each vehicle: **technology, reliability** and **durability**.

A range of products that aim at excellence, developed around who uses them: man. We work every day to evolve our vehicles, adopting the best solutions based on our research, advice and experiences with our customers.

The result is the technological content of the vehicles we produce: the set of components and their set-up guarantee an **optimal performance** level. The result is a style that stands out, because we believe that our identity is our strength.

**AGRI MAX**, the most performing among the vehicles of the Dieci agricultural range, has been redesigned on a human scale: with the new futuristic cab signed by Giugiaro Design and important interventions on comfort and performance. We have provided farmers with a **top-quality telehandler**.

## **EXCLUSIVE COMFORT** *ITALIAN DESIGN AND STYLE*

Dieci telehandler cabs have always been a combination of **comfort** and **functionality** linked with the **style** which makes us stand out all over the world. In the NEW 2018 CAB we wanted to enhance the Made in Italy with the touch of one of the most famous Italian Designers: **Giugiaro Design**.

The interiors are made of **soft touch materials** obtained from the Automotive sector, extremely soft to the touch, which ensure excellent **thermal and sound insulation**, in addition to **significantly reducing vibrations**. Aesthetics and quality combine with functionality: the passenger compartment is particularly bright thanks to the matching of soft colors and the backlighting of the pedal group, switches and access ladder. Full light and visibility also outwards, with a generous window that allows an **excellent 360° view**, LED work lights on the cab, perimeter and boom, electrically adjustable and heated wing mirrors and three wireless cameras that also inspect the most hidden points.

We want to offer the best comfort to operators, for this we have amplified the traditional comfort of the Dieci cabs with wider spaces for the legs, adjustable steering wheel and armrest, the choice of three different seat suspension systems and a **new cab shock absorption system**, unique in the telehandlers sector, able to effectively dampen the most annoying oscillations of the most uneven ground.

Finally, from research and advanced fluid dynamics studies, we have developed the new **air conditioning system** that, together with the openable roof and rear glass, ensures an optimized air distribution in order to regulate the ideal temperature in every season of the year.





## FULL COMFORT

### LARGER

- Improved ergonomics and accessibility: more space for the operator's legs

### MORE COMFORTABLE

- Cab with hydraulic shock absorbers: shocks fully absorbed
- Adjustable steering column and armrest, heated seat with 3 suspension system options: driving on a comfortable seat

## INTERIOR DESIGN

### PRECIOUS TOUCH

- Precious soft-touch interiors obtained from the Automotive industry

### THE NOISE OUTSIDE

- Soundproofed roof, instrument panel and mat insulate the cab from noise

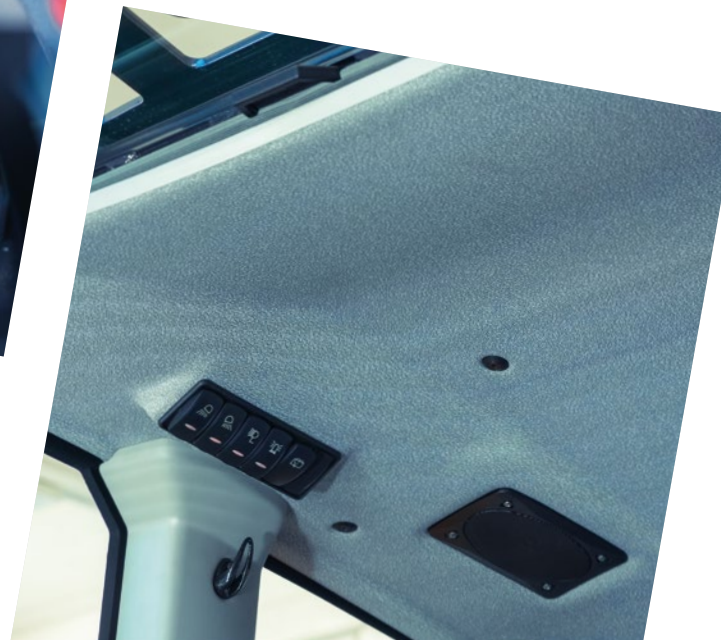

## PERFECT CLIMATE

### ALWAYS THE RIGHT TEMPERATURE

- Optimized air flows: 6 vents available, openable rear glass and roof, integrated electric lateral window
- Quick demisting of the windows

### DOUBLE AIR FILTER

- Operator protected against dust and odors



## TOTAL VISIBILITY

### PANORAMIC VIEW, ALWAYS

- Large windows: optimal visibility in all directions
- Integrated LED work lights: better view, consume less, last longer
- Headlights everywhere: perimeter, on the boom and on the boom head

### EVERYTHING UNDER CONTROL

- 7" color graphic display
- Navigation encoder
- Electrically adjustable and heated wing mirrors
- 3 wireless cameras: rear, right side and boom head in a 7" display



# PURE TECHNOLOGY

## POWER AND CONTROL

Man operates, technology empowers and controls. The new agricultural range is designed on a fully integrated and **advanced electronic vehicle management system**: an exclusive Dieci feature.

All the vehicle control functions (RPM control, speed and diagnostics) refer to a **single control unit** that measures the optimal working parameters through in-depth diagnostics, displaying them in real time, allowing the operator to always have **everything under control**. The tilting capacity and force have been increased, the boom can be fully operated on the dashboard with a **new joystick**, which also incorporates the fwd/rev selector (FNR reverse shuttle), for easier and more practical direction control.

Also the **frame** features new strength, while the **Vario System transmission** guarantees power, reactivity and control in maneuvers thanks to the integrated electronic management.





## EVOLUTION OF THE FAMILY



### AGRI MAX 50.8

↑ Maximum height 7,7 m

📊 5 t capacity



### AGRI MAX 65.8

↑ Maximum height 7,7 m

📊 6,5 t capacity



### AGRI MAX 60.9

↑ Maximum height 8,6 m

📊 6 t capacity

## ADVANCED TELESCOPIC BOOM

### ELECTRONIC COMFORT, TECHNOLOGICAL POWER

- Reinforced boom made of High Resistance Steel: more reliable
- Extension cylinder with closing shock absorber: more comfort
- Suspension electronic control according to the speed and height
- Load Sensing - Flow Sharing Distributors: more simultaneous movements for a more efficient work
- Direction of travel and boom controlled by the new CAN-bus joystick

## ATTACHMENT HOLDING PLATE

### NEW ATTACHMENT HOLDING PLATE

- Reinforced in steel
- Counter-lever articulation: greater tilting angle

### NEW AUTOMATIC COUPLING SYSTEM

- Tools recognition without manual operations: easier, maximum safety
- Immediate machine setting for different uses

### HYDRAULIC ACCESSORIES LOCK

- Double cylinder, double action, maximum stability



## VARIO SYSTEM TRANSMISSION

### STRONG AND FAST

- Maximum speed 40 km/h

### CRUISE CONTROL

- Electronic accelerator and limiter

### 4 DRIVING MODES:

- Normal
- ECO
- Loader
- Creeper









## **POWER** *FAST, ACCURATE AND ECOLOGICAL*

Power, up to 153 hp, but above all **high performance**: this is the spirit of the new engines that drive AGRI MAX family. Cutting-edge engines with fully electronic control, to optimize **power output and efficiency**. Its 4485 CC displacement develops an impressive torque at only 1500 rpm. All without renouncing to long lasting reliability and **respect for the environment**, with DOC and SCR systems to reduce atmospheric emissions according to Stage 4/Tier 4F regulations.



## **ENGINE**

### **HIGH PERFORMANCE**

- Torque up to 636 Nm at only 1500 rpm

### **ELECTRONIC EVOLUTION**

- Complete electronic control: optimized output and efficiency

### **LONG AUTONOMY**

- New top-of-range tank: 140 liters of fuel

## **CLEAN POWER**

### **MINIMUM EMISSIONS**

- Stage 4/Tier 4F system
- DOC+SCR catalysts
- 27 liter Urea tank

## **HYDRAULIC SYSTEM**

### **DOUBLE GEAR PUMP**

- Boom readiness and reactivity
- Precise and fast movements, even at high power

# THE MAN FIRST

## WE SIMPLIFY YOUR WORK

### MAINTENANCE

#### We make the vehicle as the customer wants it!

Dieci, thanks to more than half a century of experience in the telehandler sector, is proud to apply this constructive philosophy: we accept the advice of those who have already contacted us and we think about how to simplify work on a Dieci vehicle.

For the new agricultural range we have completely redesigned the **engine compartment**, with an attractive design that integrates large rear and lateral openings in the hood, so that it can be accessed more easily. Inside, the optimal arrangement of components will make **maintenance quicker and more convenient**.

The radiators are easier and faster to clean, as the new unit makes more accessible. Lubricating operations are easier and faster thanks to the automatic system. Easy life even in the passenger compartment: the air filter can be reached without any tools, while the perfectly sealed electrical system remains protected from water and dust. Also the interventions required for the change of hydraulic oil are minimal, as they are necessary only every 2000 hours of operation.



### DIECI SERVICE

Dieci Service is our technical assistance service present across the world, through an **extensive network of dealers** and authorized service centers. Our customers are assisted directly by specialized technicians and every request is satisfied in a very short time: thanks to the use of automated warehouses, Dieci Service can provide, within a few hours, interventions and spare parts all over the world.

Visit [www.dieci.com](http://www.dieci.com) to find the dealer closest to you.

**DEALERS** 400

**COUNTRIES** 70

**BRANCHES** 3

# TECHNICAL DATA

## PERFORMANCE

Machine model	AGRI MAX 50.8 VS EVO2	AGRI MAX 65.8 VS EVO2	AGRI MAX 60.9 VS EVO2
Wheels maximum capacity	5000 kg (11023 lb)	6500 kg (14330 lb)	6000 kg (13228 lb)
Maximum lifting height on wheels	7,70 m (25,3 ft)	7,70 m (25,3 ft)	8,60 m (28,2 ft)
Pull-out force	5700 daN (12814 lbf)	5700 daN (12814 lbf)	5700 daN (12814 lbf)
Towing force	7300 daN (16411 lbf)	7300 daN (16411 lbf)	7300 daN (16411 lbf)
Maximum climb angle	40%	40%	40%
Unladen weight	10000 kg (22046 lb)	11300 kg (24912 lb)	11500 kg (25353 lb)
Max speed (referred to wheels with maximum permitted diameter)	40 km/h (24,9 mph)	40 km/h (24,9 mph)	40 km/h (24,9 mph)

## ENGINE

Brand	FPT
Nominal power	103 kW (138 HP)
@rpm	2200 rpm
Peak power	114 kW (153 HP)
@rpm	1800 rpm
Displacement	4485 cm <sup>3</sup> (274 in <sup>3</sup> )
Emission standards	Stage IV/Tier 4f
Exhaust gas treatment	DOC+SCR (AdBlue)
Intake	16-valve turbo compressor, aftercooler

## HYDRAULIC SYSTEM

Hydraulic pump type	Piston pump with variable flow rate for power steering and movements Gear pumps for Fan Drive with automatic fan reversal.
Hydraulic pump capacity	247 L/min (65,3 gal/min)
Max. operating pressure	26,0 MPa (3771 psi)
Distributor control	4in1 proportional Joystick with FNR

## TRANSMISSION

Transmission type	Hydrostatic single speed Vario System EVO2 with electronic control
Hydraulic motor	2 Hydraulic motors with continuous automatic adjustment
Reversal	With electronic control operated with vehicle in motion
Inching	With electronic pedal for controlled forward movement

## DIMENSIONS

	AGRI MAX 50.8 VS EVO2	AGRI MAX 65.8 VS EVO2	AGRI MAX 60.9 VS EVO2
A	400 mm (15,7 in)	400 mm (15,7 in)	400 mm (15,7 in)
B	1186 mm (46,7 in)	1186 mm (46,7 in)	1536 mm (60,5 in)
C	2800 mm (110,2 in)	2800 mm (110,2 in)	2800 mm (110,2 in)
D	1037 mm (40,8 in)	1037 mm (40,8 in)	1037 mm (40,8 in)
E1	2800 mm (110,2 in)	2800 mm (110,2 in)	2800 mm (110,2 in)
F	4442 mm (174,9 in)	4442 mm (174,9 in)	4442 mm (174,9 in)
G	5023 mm (197,8 in)	5023 mm (197,8 in)	5373 mm (211,5 in)
H	2545 mm (100,2 in)	2545 mm (100,2 in)	2545 mm (100,2 in)
I	960 mm (37,8 in)	960 mm (37,8 in)	960 mm (37,8 in)
K01	37°	37°	37°
K03	10°	10°	10°
K06	144°	144°	144°
K07	16°	16°	16°
K08	131°	131°	131°
L	1930 mm (76 in)	1930 mm (76 in)	1930 mm (76 in)
L1	5223 mm (205,6 in)	5223 mm (205,6 in)	5561 mm (218,9 in)
M	2375 mm (93,5 in)	2375 mm (93,5 in)	2390 mm (94,1 in)
M1	1386 mm (54,6 in)	1386 mm (54,6 in)	1724 mm (67,9 in)
N1	1910 mm (75,2 in)	1910 mm (75,2 in)	1910 mm (75,2 in)
O1	6223 mm (245 in)	6223 mm (245 in)	6573 mm (258,8 in)
P	1229 mm (48,4 in)	1229 mm (48,4 in)	1229 mm (48,4 in)
P1	60 mm (2,4 in)	60 mm (2,4 in)	60 mm (2,4 in)
Q	3933 mm (154,8 in)	3933 mm (154,8 in)	3933 mm (154,8 in)
Q1	1200 mm (47,2 in)	1200 mm (47,2 in)	1200 mm (47,2 in)
R1	1200 mm (47,2 in)	1200 mm (47,2 in)	1200 mm (47,2 in)
S1	150 mm (5,9 in)	150 mm (5,9 in)	150 mm (5,9 in)
T1	4824 mm (189,9 in)	4824 mm (189,9 in)	5104 mm (200,9 in)
U1	3596 mm (141,6 in)	3596 mm (141,6 in)	3875 mm (152,6 in)
V1	8613 mm (339,1 in)	8613 mm (339,1 in)	-

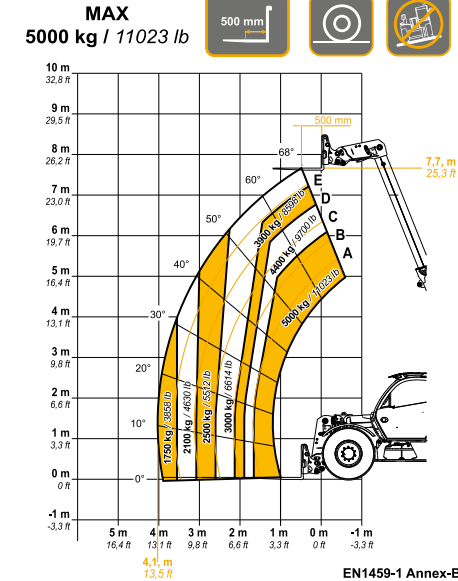
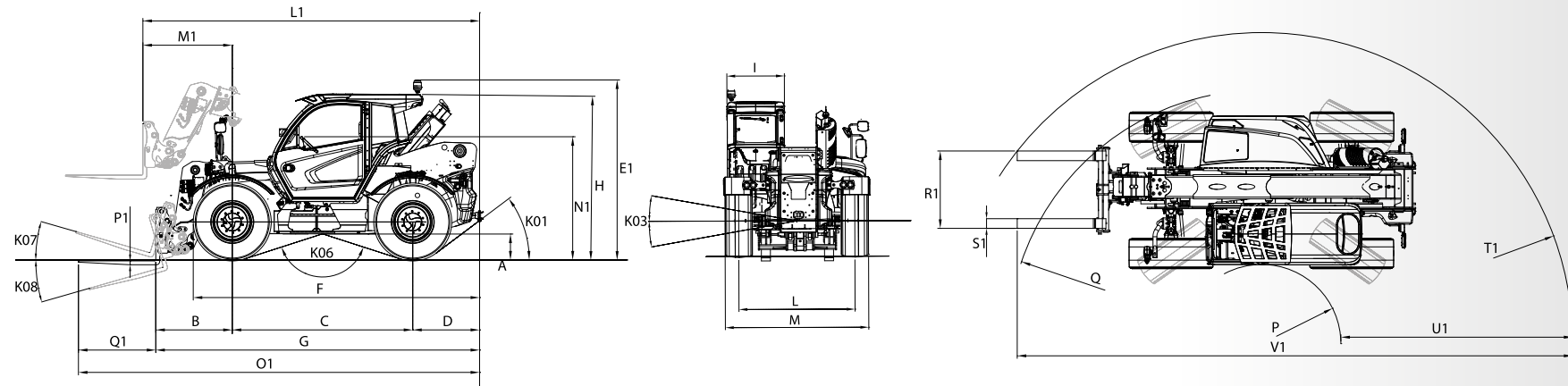

AGRI MAX 50.8

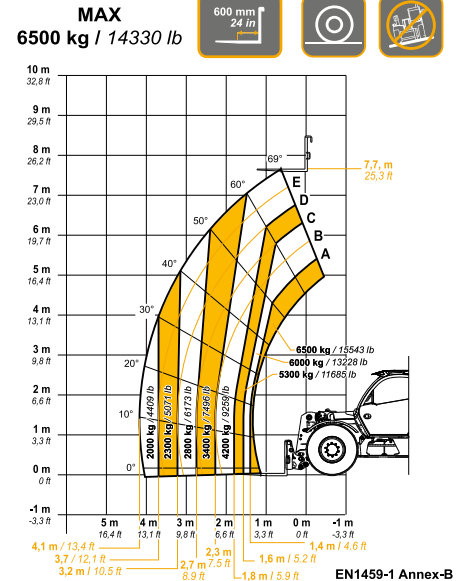

AGRI MAX 65.8

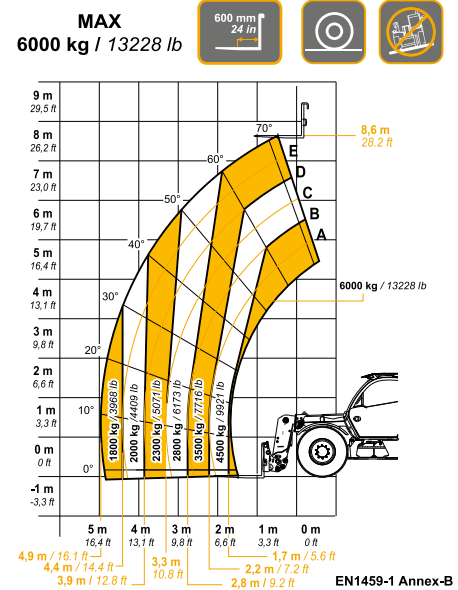

AGRI MAX 60.9

# DIECI, A STRONG COMPANY

## EXPERIENCE FOR INNOVATION

We design and build work vehicles since 1962, and today we are recognized as one of the most important global players.

Proudly Italian, with general headquarters in Emilia Romagna of over 135,000 square meters and about 400 people employed, thanks to 3 European branches in Germany, United Kingdom, France and a global network of over 400 dealers, Dieci is present in over 70 countries.

Research and development of innovative technologies, training and customer care are incessantly at the center of our activities: the result of this constant commitment is realized in an offer that includes 159 models in production, including agricultural, construction, industrial and special vehicles.

In the last 2 years we have renewed 80% of the product range, to offer our customers increasingly advanced, performing, reliable and safe solutions.

Today we introduce the new agricultural range, 4 families and 15 models with major upgrades on comfort and design, to **give value to the most important element: man.**

1962 **FOUNDED**

135.000 **m<sup>2</sup>**

400 **EMPLOYEES**

159 **MODELS**

19 **FAMILIES**

**AGRI MAX**

50.8 | 65.8 | 60.9

**DIECI**

[www.dieci.com](http://www.dieci.com)

